

Physics Curriculum Support Document



Physics Support Documents 2004 Curriculum

Public Schools of North Carolina

June 2007

Physics Curriculum Support Document

Curriculum Support for the 2004 revision of the *North Carolina Standard Course of Study for Physics*

Acknowledgements

A group of dedicated and talented science teachers sent many hours developing these materials. The result is this resource that will facilitate the implementation of the North Carolina Science Curriculum.

A special thanks to the authors of these materials:

Pamela Lovin, Physics Curriculum Committee Chairperson
Patty Blanton, Watauga High School
Melissa Drake, Southwest Edgecombe High School
Sue Eldon, Northern High School
Matt Greenwolfe, Cary Academy
Kerry Havner, North Carolina State University
Jane Kinney, Charlotte-Mecklenburg Schools
Ron Owens, Kinston High School
Linda M. Stroud, Science and Safety Consulting Services

And to the many other teachers and scientists who provided helpful comments.

We would also like to extend a special thanks to Sam Houston, The North Carolina Science, Mathematics and Technology Education Center, the Teacher Link Fellows and The Burroughs Wellcome Fund for their generous support during the development of these materials.

Comments on these materials should be addressed to:

Science Consultants
Eleanor Hasse eehasse@dpi.state.nc.us
Benita Tipton btipton@dpi.state.nc.us
Ragan Spain rspain@dpi.state.nc.us
Secondary Mathematics and Science Section
North Carolina Department of Public Instruction
6352 Mail Service Center
Raleigh, NC 27699-6352

Physics Curriculum Support Document

Table of Contents

Introduction	1
Goals	1
Unifying Concepts	2
The Strands: Nature of Science	3
Detailed Description of Content	7
Goal 1	7
Goal 2	9
Goal 3	13
Goal 4	18
Goal 5	21
Goal 6	24
Goal 7	27
Goal 8	30
Safety in the Science Classroom and Laboratory	34
Activities and labs	39
Linear Motion	40
Motion on an Inclined Surface	43
Projectile Motion	49
Centripetal Force	52
A Minilab – Components of Force Vectors	54
Newton’s Second Law	56
Newton’s Second Law – An Inquiry Approach	60
Modified Atwood's Machine Lab	62
Weight vs. Mass	65
Demonstration: Impulse is Equal to Change in Momentum	66
Conservation of Momentum	69
Spring Energy Activities	73
Waves and Springs Activities	78
Reflection and Refraction Activities	80
Doppler Effect	86
Sticky Tape Lab	88
Circuit Activity	90
Ohm’s Law Activity	91
Verifying Ohm’s Law	93
Current and Voltage for Resistors in Series, Parallel, and Mixed Circuits	101
Charts and References	116
Introduction to the North Carolina Physics Reference Tables	117
North Carolina Physics Reference Tables	118
Variables and Units of Measure Chart	122
Essential Resources (WEB simulations included here)	129
Physics Curriculum Comparison	136
Alternative sequencing schemes for physics	139
Bibliography	141
Honors Physics	142

Physics Curriculum Support Document

Acknowledgements.....	142
Introduction to Honors Science Courses	143
Introduction to Honors Physics	146
Honors Physics Course Description	148
Suggestions for Honors Physics	149
Activities and Labs	
Just Do It	150
Catapult Project	156
Too Hot Research	161
Independent Investigation Sample Rubric	166

Physics Curriculum Support Document

Introduction

Introduction

This support document includes the *North Carolina Standard Course of Study* goals and objectives for Physics along with detailed content description, a list of enrichment topics, and a collection of activities. These materials are intended to serve as guides and resources for classroom teachers.

The particular laboratory investigations and classroom activities in the support document are not required but if these activities are not done then similar laboratory investigations should be substituted. **The physics course is designed to be a laboratory course.**

The detailed content descriptions should serve as a minimum and not a maximum for physics courses. Vocabulary was intentionally minimized to provide teachers time to develop conceptual understanding of the topics. The recommended number of days is approximate, based on 180 days of instruction and will need to be adjusted to fit the actual number of instructional days in each school, and the particular needs of the students. Also teachers may choose to combine topics and objectives from different goals in project based learning or thematic units.

Goal 1 is included to emphasize the importance of science as inquiry. Students should be provided many opportunities throughout the course to design and carry out investigations and to analyze and evaluate data. They should be required to present their data and explain their conclusions.

Goals

Physics, the most fundamental of the natural sciences, is quantitative in nature and uses the language of mathematics to describe natural phenomena. Inquiry is applied to the study of matter and energy and their interaction. Learners will study natural and technological systems. The program strands and unifying concepts provide a context for teaching content and process skill goals. All goals should focus on the unifying concepts:

- Systems, Order and Organization
- Evidence, Models, and Explanation
- Constancy, Change, and Measurement
- Evolution and Equilibrium
- Form and Function.

Strands: The strands are: Nature of Science, Science as Inquiry, Science and Technology, Science in Personal and Social Perspectives. They provide the context for teaching of the content Goals and Objectives.

Physics Curriculum Support Document

Unifying Concepts

Unifying Concepts

The following unifying concepts should unite the study of various physics topics across grade levels. Focus on the unifying concepts of science will also help students to understand the constant nature of science across disciplines and time even as scientific knowledge, understanding and procedures change.

Unifying Concepts	Topics which demonstrate these concepts
Systems, Order and Organization	<ul style="list-style-type: none">• Graphical relationships in kinematics• Newton's Laws of Motion
Evidence, Models, and Explanation	<ul style="list-style-type: none">• Nature of static electricity• Conservation of momentum
Constancy, Change, and Measurement	<ul style="list-style-type: none">• Projectile motion• Centripetal force• Wave energy
Evolution and Equilibrium	<ul style="list-style-type: none">• Newton's Laws of Motion• Conservation of energy
Form and Function	<ul style="list-style-type: none">• Energy storage-kinetic, potential, etc.• Electrical circuits

Physics Curriculum Support Document

The Strands: The Nature of Science

The Strands: Nature of Science

This strand includes the following sections: Science as a Human Endeavor, Historical Perspectives, and the Nature of Scientific Knowledge. These sections are designed to help students understand the human dimensions of science, the nature of scientific thought, and the role of science in society. Physics is rich in examples of science as a human endeavor, historical perspectives on the development of scientific understanding, and the nature and role of science.

Strands	Ideas for integrating these strands
<p><i>Science as a Human Endeavor</i></p> <p>Intellectual honesty and an ethical tradition are hallmarks of the practice of science. The practice is rooted in accurate data reporting, peer review, and making findings public. This aspect of the nature of science can be implemented by designing instruction that encourages students to work collaboratively in groups to design investigations, formulate hypotheses, collect data, reach conclusions, and present their findings to their classmates.</p> <p>The content studied in physics provides an opportunity to present science as the basis for engineering, electronics, computer science, astronomy and the technical trades. The diversity of physics content allows for looking at science as a vocation. Scientist, artist, and technician are just a few of the many careers in which a physics background is necessary.</p> <p>Perhaps the most important aspect of this strand is that science is an integral part of society and is therefore relevant to students' lives.</p>	<ul style="list-style-type: none"> • Design inquiry activities which all students to collect data and report their finding to their peers for review. • Encourage students to explore how physics is an integral part of the many diverse vocations. • Demonstrate using newspaper and magazine articles the importance of understanding physics.
<p><i>Historical Perspectives</i></p> <p>Most scientific knowledge and technological advances develop incrementally from the labors of scientists and inventors. Although science history includes accounts of serendipitous scientific discoveries, most development of scientific concepts and technological innovation occurs in response to a specific problem or conflict. Both great advances and gradual knowledge-building in science and technology have profound effects on society. Students should appreciate the scientific thought and effort of the individuals who contributed to these advances. Galileo's struggle to correct the misconceptions arising from Aristotle's explanation of the behavior of falling bodies led to Newton's deductive approach to motion in <i>The Principia</i>. Today, Newton's Law of Universal Gravitation and his laws of motion are used to predict the landing sites for NASA's space flights.</p>	<ul style="list-style-type: none"> • Allow student to investigate the diverse group of scientists and cultures who have contributed to our understanding of physics. • Key scientist to help understand their contributions (This is list is not comprehensive or required but should serve as a guide.) <ul style="list-style-type: none"> ▪ Newton ▪ Joule ▪ Ohm ▪ Galileo

Physics Curriculum Support Document

The Strands: The Nature of Science

Strands	Ideas for integrating these strands
<p data-bbox="183 247 800 348"><i>Nature of Scientific Knowledge</i> Much of what is understood about the nature of science must be explicitly addressed:</p> <ul data-bbox="237 352 800 1356" style="list-style-type: none"><li data-bbox="237 352 800 441">• All scientific knowledge is tentative, although many ideas have stood the test of time and are reliable for our use.<li data-bbox="237 445 800 840">• Theories "explain" phenomena that we observe. They are never proved; rather, they represent the most logical explanation based on the currently available evidence. Theories become stronger as more supporting evidence is gathered. They may be modified as new data are gathered or existing data are interpreted in different ways. They provide a context for further research and give us a basis for prediction. For example, the Theory of Relativity explains the behavior of objects accelerating at velocities approaching the speed of light.<li data-bbox="237 844 800 997">• Laws are fundamentally different from theories. They are universal generalizations based on observations of the natural world, such as the nature of gravity, the relationship of forces and motion, and the nature of planetary movement.<li data-bbox="237 1001 800 1356">• Scientists, in their quest for the best explanations of natural phenomena, employ rigorous methods. Scientific explanations must adhere to the rules of evidence, make predictions, be logical, and be consistent with observations and conclusions. "Explanations of how the natural world changes based on myths, personal beliefs, religious values, mystical inspiration, superstition, or authority may be personally useful and socially relevant, but they are not scientific." (National Science Education Standards, 1996, p 201)	<ul data-bbox="873 247 1435 546" style="list-style-type: none"><li data-bbox="873 247 1435 325">• Emphasize how the understanding of gravity has changed over time.<li data-bbox="873 357 1435 434">• Encourage students to explore the difference in a theory and a law.<li data-bbox="873 466 1435 546">• Remind students how scientific explanations undergo rigorous scrutiny.

Physics Curriculum Support Document

The Strands: The Nature of Science

Strands	Ideas for integrating these strands
<p><i>Science as Inquiry</i></p> <p>Inquiry should be the central theme in physics. It is an integral part of the learning experience and may be used in both traditional class problems and laboratory work. The essence of the inquiry process is to ask questions that stimulate students to think critically and to formulate their own questions. Observing, classifying, using numbers, plotting graphs, measuring, inferring, predicting, formulating models, interpreting data, hypothesizing, and experimenting all help students to build knowledge and communicate what they have learned. Inquiry is the application of creative thinking to new and unfamiliar situations. Students should learn to design solutions to problems that interest them. This may be accomplished in a variety of ways, but situations that present a discrepant event or ones that challenge students' intuitions have been successful.</p> <p>Classical experiments such as measuring inertia and the speed of falling bodies need not be excluded. Rather, they should be a prelude to open-ended investigations in which students have the chance to pose questions, design experiments, record and analyze data, and communicate their findings. For example, after measuring the relationships among force, mass, and acceleration of falling bodies, students might investigate the phenomenon of "weightlessness."</p> <p>Although original student research is often relegated to a yearly science fair project, continuing student involvement in research contributes immensely to their understanding of the process of science and to their problem-solving abilities. Physics provides much potential for inquiries. "Would it be easier to identify the location of a sound source in water or in air?" "Why?" "Would the passengers in a head-on collision between two automobiles be safer if the cars bounced off of each other or if they stuck together?" "Why?" The processes of inquiry, experimental design, investigation, and analysis are as important as finding the correct answer. Students will master much more than facts and acquisition of manipulative skills; they will learn to be critical thinkers.</p> <p>A solid conceptual base of scientific principles, as well as knowledge of science safety, is necessary for inquiry. Students should be given a supportive learning environment based on how scientists and engineers work. Adherence to all science safety criteria and guidelines for classroom, field, and laboratory experiences is imperative. Contact the Science Section at DPI for information and professional development opportunities regarding North Carolina specific Science Safety laws, codes, and standards. The Science Section is spearheading a statewide initiative entitled <i>NC-The Total Science Safety System</i>.</p>	<ul style="list-style-type: none"> • Because of the importance of science as inquiry this aspect has been integrated into Goal 1: The learner will develop abilities necessary to do and understand scientific inquiry. • This idea should be integrated into the entire course and not just taught as a separate "lab introduction" unit.

Physics Curriculum Support Document

The Strands: The Nature of Science

Strands	Ideas for integrating these strands
<p><i>Science and Technology</i></p> <p>It is impossible to learn science without developing some appreciation of technology. Therefore, this strand has a dual purpose: (a) developing students' knowledge and skills in technological design, and (b) enhancing their understanding of science and technology. The methods of scientific inquiry and technological design share many common elements - objectivity, clear definition of the problem, identification of goals, careful collection of observations and data, data analysis, replication of results, and peer review. Technological design differs from inquiry in that it must operate within the limitations of materials, scientific laws, economics, and the demands of society. Together, science and technology present many solutions to problems of survival and enhance the quality of life. Technological design is important to building understanding in physics. Telescopes, lasers, transistors, graphing calculators, personal computers, and photo gates, for example, have changed our lives, increased our knowledge of physics, and improved our understanding of the universe.</p>	<ul style="list-style-type: none"> • Provide opportunities for students to utilize technology to collect and analyze data in laboratory settings. • Allow students to brainstorm ways that technology can be used to enhance scientific study in the future. • Discuss the limitation of technology in scientific study
<p><i>Science in Personal and Social Perspectives</i></p> <p>This strand helps students in making rational decisions in the use of scientific and technological knowledge. "Understanding basic concepts and principles of science and technology should precede active debate about the economics, policies, politics, and ethics of various science and technology-related challenges. However, understanding science alone will not resolve local, national, or global challenges. (NSES, p. 199). The NSES emphasizes that "students should understand the appropriateness and value of basic questions 'What can happen?' - 'What are the odds?' and 'How do scientists and engineers know what will happen?'" (NSES, p. 199). Students should understand the causes and extent of science-related challenges. They should become familiar with the advances that proper application of scientific principles and products have brought to environmental enhancement, better energy use, reduced vehicle emissions, and improved human health.</p>	<ul style="list-style-type: none"> • Design scientific resolutions for local or global challenges. • Encourage debate about these resolutions and their consequences. • Research how science has help create new and improved products for public use, such as NASA developments.

Physics Curriculum Support Document

Goal 1

Detailed Description of Content

COMPETENCY GOAL 1: The learner will develop abilities necessary to do and understand scientific inquiry.	
Recommended number of DAYS: Goal 1 should be incorporated throughout the course in every other goal.	
<i>Objective</i>	<i>Content Description</i>
1.01 Identify questions and problems that can be answered through scientific investigations.	<ul style="list-style-type: none"> • Develop questions for investigation from a given topic or problem.
1.02 Design and conduct scientific investigations to answer questions about the physical world. <ul style="list-style-type: none"> • Create testable hypotheses. • Identify variables. • Use a control or comparison group when appropriate. • Select and use appropriate measurement tools. • Collect and record data. • Organize data into charts and graphs. • Analyze and interpret data. • Communicate findings. 	<ul style="list-style-type: none"> • Distinguish and appropriately graph dependent and independent variables. • Discuss the best method of graphing/presenting particular data. • Use technology resources such as graphing calculators and computers to analyze data. • Report and share investigation results with others.
1.03 Formulate and revise scientific explanations and models using logic and evidence to: <ul style="list-style-type: none"> • Explain observations. • Make inferences and predictions. • Explain the relationship between evidence and explanation. 	<ul style="list-style-type: none"> • Use questions and models to determine the relationships between variables in investigations. • Use evidence from an investigation to support a hypothesis.
1.04 Apply safety procedures in the laboratory and in field studies: <ul style="list-style-type: none"> • Recognize and avoid potential hazards. • Safely manipulate materials and equipment needed for scientific investigations. 	<ul style="list-style-type: none"> • Predict safety concerns for particular experiments <ul style="list-style-type: none"> ○ Electricity ○ Projectiles • Relate physics concepts to safety applications such as: <ul style="list-style-type: none"> ○ Transportation: seat belts, air bags, speed... ○ Short circuits, circuit breakers, fire hazards

Physics Curriculum Support Document

Goal 1

COMPETENCY GOAL 1: The learner will develop abilities necessary to do and understand scientific inquiry.	
Recommended number of DAYS: Goal 1 should be incorporated throughout the course in every other goal.	
<i>Objective</i>	<i>Content Description</i>
1.05 Analyze reports of scientific investigations of physical phenomena from an informed scientifically literate viewpoint including considerations of: <ul style="list-style-type: none">• Adequacy of experimental controls.• Replication of findings.• Alternative interpretations of the data.	<ul style="list-style-type: none">• Read a variety of scientific research reports. Some appropriate sources include:<ul style="list-style-type: none">○ Science News Online http://www.sciencenews.org/ The for Kids section of this website has great summaries with links to the next level.○ Science Daily http://www.sciencedaily.com/○ Tuesday New York Times Science Section○ Scientific American

Physics Curriculum Support Document

Goal 2

COMPETENCY GOAL 2: The learner will build an understanding of linear motion.			
Days/ 180	Objective	Content Description	Suggested activities
5/180	<p>2.01 Analyze velocity as a rate of change of position:</p> <ul style="list-style-type: none"> • Average velocity. • Instantaneous velocity. 	<ul style="list-style-type: none"> • Identify a frame of reference for measurement of position and identify the initial position of the object. • Develop the definition of velocity as the rate of change of position conceptually, mathematically and graphically (see 2.04). • Apply the equation developed to several applications where objects are moving with constant velocity: $\bar{v} = \frac{\Delta x}{\Delta t}$ $x_f = x_i + vt$	<ul style="list-style-type: none"> • Inquiry Support Lab: Linear Motion • Inquiry Support Lab: Motion on an Inclined Surface • Enrichment: Special Relativity • Enrichment: Use a motion detector to find the speed of sound • Enrichment: Use a microwave to find the speed of light
2/180	<p>2.02 Compare and contrast as scalar and vector quantities:</p> <ul style="list-style-type: none"> • Speed and velocity. • Distance and displacement. 	<ul style="list-style-type: none"> • Define <i>vector</i> and <i>scalar</i>, incorporating magnitude and direction. • Apply concepts of speed and velocity to solve conceptual and quantitative problems. • Distinguish between distance and displacement conceptually and mathematically. • Solve quantitative problems involving distance and displacement. • Clarify that a positive value for velocity indicates motion in one direction while a negative value indicates motion in the opposite direction. 	<ul style="list-style-type: none"> • Enrichment: Indirectly measure the height of a building or flagpole.

Physics Curriculum Support Document

Goal 2

COMPETENCY GOAL 2: The learner will build an understanding of linear motion.			
Days/ 180	Objective	Content Description	Suggested activities
9/180	2.03 Analyze acceleration as rate of change in velocity.	<ul style="list-style-type: none"> Develop the definition for constant (uniform) acceleration as the rate of change of velocity conceptually, mathematically, and graphically (see 2.04). Analyze visual representations of constant and changing velocity. (see 2.04) Use kinematics equations for acceleration: $x_f = x_i + v_i t + \frac{1}{2} a t^2$ $a = \frac{\Delta v}{\Delta t}$ $v_f^2 = v_i^2 + 2a\Delta x$ Apply concepts of constant (uniform) acceleration to objects in free fall. 	<ul style="list-style-type: none"> Making an accelerometer using a fishing bob in an upside down bottle full of water Enrichment: Matching graphs using a motion detector. Enrichment: Picket fence
13/180	2.04 Using graphical and mathematical tools, design and conduct investigations of linear motion and the relationships among: <ul style="list-style-type: none"> Position. Average velocity. Instantaneous velocity Acceleration. Time. 	Constant velocity: <ul style="list-style-type: none"> Measure position versus time of an object moving with constant velocity. Plot a position versus time graph of the measurements. Recognize that the relationship is linear and construct a best-fit line. Identify the slope of the line as the change in position over time (velocity) and the y-intercept as the initial position for the given time interval. Using the slope y-intercept equation ($y = mx + b$) from the graphs above, derive the mathematical relationships: 	<ul style="list-style-type: none"> Develop a “ticker tape” or “motion map” representation of the motion (position of the object at equal time readings). Give several examples of graphs and “motion maps” of position vs. time (equally spaced dots...distance between dots is representative of speed) including: constant positive velocity starting at position 0

Physics Curriculum Support Document

Goal 2

COMPETENCY GOAL 2: The learner will build an understanding of linear motion.			
<i>Days/ 180</i>	<i>Objective</i>	<i>Content Description</i>	<i>Suggested activities</i>
		<ul style="list-style-type: none"> ○ <i>final position = average velocity * time + initial position</i> ○ <i>final position - initial position = average velocity * time</i> ○ $\bar{v} = \frac{\Delta x}{\Delta t}$ ● Define change in position as <i>displacement</i> and show the average velocity equation $(\bar{v} = \frac{\Delta x}{\Delta t})$. <p>Constant acceleration:</p> <ul style="list-style-type: none"> ● Measure position and time of an object moving with constant acceleration. ● Plot a position vs. time graph of the measurements. ● Recognize that the relationship is not linear but fits the shape of a parabola indicating that position is proportional to time squared. ● At various points on the curve, draw lines tangent to the curve and develop the concept of instantaneous velocity (represented by the slope of the tangent line at that time instant). ● Give several examples of and compare position vs. time, velocity vs. time and acceleration vs. time graphs. ● Recognize that the slope of the line on an instantaneous velocity vs. time graph is the acceleration. 	<p>(object moving away from the starting point); constant negative velocity starting at some position other than 0 (object moving toward position 0); and two objects with different velocities on the same graph.</p> <ul style="list-style-type: none"> ● Give several examples of graphs and “motion maps” of position vs. time (distances between the dots getting larger or smaller as the object is accelerating) and graphs showing constant positive acceleration and constant negative acceleration: positive direction speeding up or slowing down, negative direction speeding up or slowing down ● Things to use that travel at constant velocity: <ul style="list-style-type: none"> ○ Battery driven cars (Flip-over Dune buggy, Stomper cars)

Physics Curriculum Support Document

Goal 2

COMPETENCY GOAL 2: The learner will build an understanding of linear motion.			
<i>Days/ 180</i>	<i>Objective</i>	<i>Content Description</i>	<i>Suggested activities</i>
		<ul style="list-style-type: none"> Develop the equations for objects that are experiencing constant acceleration (rolling down an inclined plane or objects falling toward the earth): $x_f = x_i + v_i t + \frac{1}{2} a t^2$ $a = \frac{\Delta v}{\Delta t}$ $v_f^2 = v_i^2 + 2a\Delta x$ 	<ul style="list-style-type: none"> ○ Bowling ball rolled along a smooth floor • Things that accelerate at a constant rate: <ul style="list-style-type: none"> ○ Objects (balls, carts) rolling down a smooth, constant incline ○ Hot wheel cars on a track of constant slope ○ Marbles down a clear pipe

Physics Curriculum Support Document

Goal 3

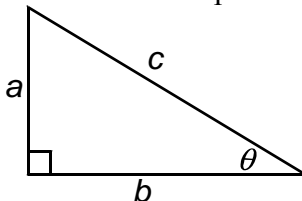
COMPETENCY GOAL 3: The learner will build an understanding of two-dimensional motion including circular motion.			
<i>Days/ 180</i>	<i>Objective</i>	<i>Content Description</i>	<i>Suggested activities</i>
4/180	3.01 Analyze and evaluate projectile motion in a defined frame of reference.	<ul style="list-style-type: none"> • Resolve vectors into vertical and horizontal components: <div style="text-align: center; margin: 10px 0;">  </div> $a^2 + b^2 = c^2$ $\sin \theta = \frac{a}{c}$ $\cos \theta = \frac{b}{c}$ $\tan \theta = \frac{a}{b}$ <ul style="list-style-type: none"> • Evaluate the motion of a projectile both horizontally and vertically. <ul style="list-style-type: none"> ○ Recognize that the horizontal component of velocity does not change (neglecting air resistance). ○ Recognize that the vertical component of velocity does change due to gravity at the rate of 9.8m/s^2 downward. 	<ul style="list-style-type: none"> • Video analysis of “Monkey and Gun” – using a wide variety of equipment • Enrichment: Trebuchets • Enrichment: Water balloon launchers • Enrichment: Tennis ball launchers • Enrichment: Model rockets • Enrichment: Bottle (2L variety) rockets
4/180	3.02 Design and conduct investigations of two-dimensional motion of objects.	<ul style="list-style-type: none"> • Select appropriate measurements for an investigation of projectile motion. • Identify factors that may affect results. • Predict and measure the path of the projectile including horizontal range, maximum height, and time in flight (such as a projectile launched horizontally or from the 	<ul style="list-style-type: none"> • Projectile Motion as illustrated by a Basketball Shot <u>Inquiry Support Lab: Projectile Motion</u>

Physics Curriculum Support Document

Goal 3

COMPETENCY GOAL 3: The learner will build an understanding of two-dimensional motion including circular motion.			
<i>Days/ 180</i>	<i>Objective</i>	<i>Content Description</i>	<i>Suggested activities</i>
		ground at a given angle).	
5/180	3.03 Analyze and evaluate independence of the vector components of projectile motion.	<ul style="list-style-type: none"> Recognize that vector components are independent of each other. Apply the equations of uniform velocity to the horizontal component. Apply the equations of accelerated motion to the vertical component of velocity. Relate height, time in air and initial vertical velocity (such as a projectile launched horizontally or from the ground at a given angle). Relate range of projectile, time and initial horizontal velocity (such as a projectile launched horizontally or from the ground at a given angle). Relate height and time in the air to the initial vertical velocity Relate range of projectile to time in flight and initial horizontal velocity 	
3/180	3.04 Evaluate, measure, and analyze circular motion.	<ul style="list-style-type: none"> Recognize that an object may move with constant speed but changing velocity. Recognize that the directions of the velocity and acceleration vectors are perpendicular to each other. Understand that centripetal acceleration is a consequence of the changing velocity due to change in direction. Design and conduct investigations of circular 	

Physics Curriculum Support Document

Goal 3

COMPETENCY GOAL 3: The learner will build an understanding of two-dimensional motion including circular motion.			
Days/ 180	Objective	Content Description	Suggested activities
		<p>motion.</p> <ul style="list-style-type: none"> Experimentally verify the proportional relationships described in 3.06. Combine proportional relationships into a single equation. Calculate velocity using radius or circumference of the circle and time to complete one or more circuits. Calculate centripetal acceleration as the velocity squared divided by the radius: $a_c = \frac{v^2}{r}$ 	
4/180	3.05 Analyze and evaluate the nature of centripetal forces.	<ul style="list-style-type: none"> Evaluate and understand that a net force is required to change the direction of a velocity vector. Understand that for uniform circular motion the net force is called the centripetal force. Understand that the centripetal force is not the result of circular motion but must be provided by an interaction with an external source. Evaluate the direction of the force and acceleration vectors as pointing to the center of the circle in the case of constant speed but not constant acceleration. 	<ul style="list-style-type: none"> Enrichment: Recognize that a horizontal highway curve should be designed and laid out to have a <i>radius of curvature</i> r that <i>changes</i> along its length L, so there will not be an abrupt change in centripetal force acting on the car and driver at the transition points between the straight highway segments and the curve. Explain why the simple equation:

Physics Curriculum Support Document

Goal 3

COMPETENCY GOAL 3: The learner will build an understanding of two-dimensional motion including circular motion.			
<i>Days/ 180</i>	<i>Objective</i>	<i>Content Description</i>	<i>Suggested activities</i>
			$\frac{1}{r} = \frac{4s(L-s)}{r_m L^2}$ <p>for the <i>curvature</i> (inverse of the radius of curvature) will achieve that objective, where s is the distance from the beginning of the curve (measured from either end) and r_m is the radius of curvature at mid-length. (Recognize that the radius of curvature of a straight line is infinite.)</p>

Physics Curriculum Support Document

Goal 3

COMPETENCY GOAL 3: The learner will build an understanding of two-dimensional motion including circular motion.			
<i>Days/ 180</i>	<i>Objective</i>	<i>Content Description</i>	<i>Suggested activities</i>
3/180	<p>3.06 Investigate, evaluate and analyze the relationship among:</p> <ul style="list-style-type: none"> • Centripetal force. • Centripetal acceleration. • Mass. • Velocity. • Radius. 	<ul style="list-style-type: none"> • Design and conduct an investigation of circular motion. • Apply the proportional relationship between force and speed squared when radius is constant. • Apply the inverse relationship between force and radius when speed is constant. • Apply the formula for centripetal force as mass times centripetal acceleration using the following equations: $a_c = \frac{v^2}{r}$ $F_c = \frac{mv^2}{r}$ 	<ul style="list-style-type: none"> • <u>Inquiry Support Lab: Centripetal Force</u>

Physics Curriculum Support Document

Goal 4

COMPETENCY GOAL 4: The learner will develop an understanding of forces and Newton's Laws of Motion.			
Days	Objective	Content Description	Suggested activities
5/180	4.01 Determine that an object will continue in its state of motion unless acted upon by a net outside force (Newton's First Law of Motion, The Law of Inertia).	<ul style="list-style-type: none"> Observe motion and draw force diagrams for objects moving at constant velocity with very little friction (examples: air track, air puck, balloon puck, dry ice) Identify that the state of motion must be a constant velocity, including zero velocity, unless acted upon by a net force. Define inertia. 	<ul style="list-style-type: none"> <u>Inquiry Support Lab: A Minilab -- Components of Force Vectors</u>
7/180	4.02 Assess, measure and calculate the conditions required to maintain a body in a state of static equilibrium.	<ul style="list-style-type: none"> Describe forces as interactions between two objects, including contact and forces at a distance. Recognize that force is a vector quantity. Define normal force. Represent the forces acting on an object using a force diagram. Analyze force diagrams to calculate the net force on an object. Determine that the net force acting on an object in static equilibrium is zero. Design and conduct investigations of objects in static equilibrium. (<i>Torque and rotational equilibrium are enrichment topics.</i>) 	<ul style="list-style-type: none"> Enrichment: Torque Enrichment: Rotational equilibrium
7/180	4.03 Assess, measure, and calculate the relationship among the force acting on a body, the mass of the body, and the nature of the acceleration produced (Newton's Second Law of Motion).	<ul style="list-style-type: none"> Design and conduct investigations of force and acceleration. Experimentally verify the proportional relationships among acceleration, force and mass. Apply proportional reasoning to the relationship between 	<ul style="list-style-type: none"> <u>Inquiry Support Lab: Newton's Second Law</u> <u>Inquiry Support Lab: Newton's Second Law – An Inquiry Approach</u> <u>Inquiry Support Lab: Modified</u>

Physics Curriculum Support Document

Goal 4

COMPETENCY GOAL 4: The learner will develop an understanding of forces and Newton's Laws of Motion.			
Days	Objective	Content Description	Suggested activities
		<p>force and acceleration when mass is constant.</p> <ul style="list-style-type: none"> Apply proportional reasoning to the inverse relationship between mass and acceleration when force is constant. Analyze force diagrams for accelerating objects. (solve for mass, acceleration, various forces) Calculate the net force on an object: $F_{\text{net}} = ma$ 	<p>Atwood's Machine Lab</p>
4/180	4.04 Analyze and mathematically describe forces as interactions between bodies (Newton's Third Law of Motion).	<ul style="list-style-type: none"> Identify interaction pairs of forces for contact forces and forces at a distance. Analyze Newton's Third Law as the relationship evidenced by $\text{Force of Object A on Object B} = - \text{Force of Object B on Object A}$ Observe and experimentally measure equal and opposite forces using pairs of spring scales or force sensors. 	
4/180	4.05 Assess the independence of the vector components of forces.	<ul style="list-style-type: none"> Resolve forces into components. Apply Newton's Laws of Motion to the perpendicular components of force in the following examples: <ol style="list-style-type: none"> objects pulled or pushed along a horizontal surface by a force at an angle to the surface; objects sliding down an inclined plane; three concurrent forces acting on an object in static equilibrium. 	<ul style="list-style-type: none"> Enrichment: Discuss how the angle of bank should change along the curve's length for maximum safety. (Relates to 3.05 enrichment)
4/180	4.06 Investigate, measure, and analyze the nature and	<ul style="list-style-type: none"> Describe friction as a contact force. 	Enrichment: coefficient of friction.

Physics Curriculum Support Document

Goal 4

COMPETENCY GOAL 4: The learner will develop an understanding of forces and Newton's Laws of Motion.			
<i>Days</i>	<i>Objective</i>	<i>Content Description</i>	<i>Suggested activities</i>
	magnitude of frictional forces.	<ul style="list-style-type: none"> Distinguish between static friction and kinetic friction. Solve quantitative problems with frictional forces. (<i>coefficient of friction is an enrichment topic</i>) 	
5/180	4.07 Assess and calculate the nature and magnitude of gravitational forces (Newton's Law of Universal Gravitation).	<ul style="list-style-type: none"> Calculate gravitational force between any two masses: $F = \frac{Gm_1m_2}{d^2}$ Apply proportional reasoning to the inverse square relationship between gravitational force and the distance between the centers of two known masses. Apply proportional reasoning to the direct relationship between gravitational force and the product of masses. Determine the force of gravity (weight) of an object: $F_g = mg$ 	<ul style="list-style-type: none"> <u>Inquiry Support Lab: Weight vs. Mass</u>

Physics Curriculum Support Document

Goal 5

COMPETENCY GOAL 5: The learner will build an understanding of impulse and momentum.			
<i>Days/180</i>	<i>Objective</i>	<i>Content Description</i>	<i>Suggested activities</i>
2/180	5.01 Assess the vector nature of momentum and its relation to the mass and velocity of an object.	<ul style="list-style-type: none"> Define momentum. Identify that momentum is a vector quantity because velocity is a vector quantity. Recognize that momentum is proportional to mass and proportional to velocity. Apply the momentum equation: $p = mv$ 	
2/180	5.02 Compare and contrast impulse and momentum.	<ul style="list-style-type: none"> Define impulse. State that impulse is equal to change in momentum: $F \Delta t = \Delta p = m \Delta v$ Recognize that the change in momentum of an object is proportional to the force applied to the object and to the time the force is applied to the object. 	<ul style="list-style-type: none"> <u>Inquiry Support Lab: Demonstration: Impulse is Equal to Change in Momentum</u>
3/180	5.03 Analyze the factors required to produce a change in momentum.	<ul style="list-style-type: none"> Distinguish between impulse and force. Determine the change in momentum of an object by finding the area under the “curve” on a force vs. time graph. Show that the larger the mass of an object, the smaller the change in velocity of an object for a given impulse. Apply the impulse equation in various situations: $F \Delta t = \Delta p = m \Delta v$ 	<ul style="list-style-type: none"> Ranking tasks on impulse and change in momentum.
5/180	5.04 Analyze one-dimensional interactions between objects and recognize that the total momentum is conserved in both collision and recoil	<ul style="list-style-type: none"> Verify that the total momentum before an interaction is equal to the total momentum after an interaction as long as there are no outside forces. Solve problems using conservation of momentum 	<ul style="list-style-type: none"> <u>Inquiry Support Lab: Conservation of Momentum</u>

Physics Curriculum Support Document

Goal 5

COMPETENCY GOAL 5: The learner will build an understanding of impulse and momentum.			
Days/ 180	Objective	Content Description	Suggested activities
	situations.	<p>in the following instances:</p> <ul style="list-style-type: none"> ○ two objects initially at rest push each other apart; ○ a moving object collides with a stationary object and the two objects stick together; ○ a moving object collides with a stationary object and the two objects move off separately; ○ two moving objects collide and either stick together or move off separately. <ul style="list-style-type: none"> ● Design and conduct investigations verifying the conservation of momentum in the four situations listed above. ● Identify the special case of an elastic collision (recoil) where the objects do not stick together <i>and</i> both momentum and kinetic energy are conserved. 	
2/180	5.05 Assess real world applications of the impulse and momentum, including but not limited to, sports and transportation.	<ul style="list-style-type: none"> ● Use examples, such as baseball and golf, to explain that “follow through” is a strategy for increasing the impulse on the ball. ● Solve collision problems. (Momentum is conserved - assume the system is limited to the colliding objects. Example: car crash.) ● Recognize elastic collisions: <ul style="list-style-type: none"> ○ ideal gas molecules collide elastically <i>billiard balls are frequently used as examples of elastic</i> 	<p><u>Demonstration for Applying Impulse</u> (adapted from a demonstration by David Green and Ted Oakley at Jordan High School in Durham, NC):</p> <ul style="list-style-type: none"> ● Throw a raw egg against a sagging sheet – no matter how hard the egg is thrown into the sheet the egg will not break. Throw the same egg

Physics Curriculum Support Document

Goal 5

COMPETENCY GOAL 5: The learner will build an understanding of impulse and momentum.			
<i>Days/ 180</i>	<i>Objective</i>	<i>Content Description</i>	<i>Suggested activities</i>
		<i>collisions.</i>	<p>against the wall (or whiteboard or some other easy to clean surface) – even if the egg has a very small velocity it will break.</p> <ul style="list-style-type: none"> • Use this demonstration to show that a large stopping time (as the sheet gives when the egg hits it) results in a small force, and a small stopping time (when the wall stops the egg almost instantaneously) results in a large force. • Relate this demonstration to the advantages of hitting an air bag in your car over hitting the dashboard.

Physics Curriculum Support Document

Goal 6

COMPETENCY GOAL 6: The learner will develop an understanding of energy as the ability to cause change.			
Days	Objective	Content Description	Suggested activities
7/180	<p>6.01 Investigate and analyze energy storage and transfer mechanisms:</p> <ul style="list-style-type: none"> • Gravitational potential energy. • Elastic potential energy. • Thermal energy. • Kinetic energy. 	<ul style="list-style-type: none"> • Develop the concept of energy as the ability to cause change. • Describe energy transfer and storage in different physical systems, including but not limited to those involving gravitational potential energy, elastic potential energy, thermal energy, and kinetic energy. • Apply proportional reasoning to the relationship between an object's kinetic energy and the object's mass and velocity according to the equation: $KE = \frac{1}{2}mv^2$ • Analyze changes in gravitational potential energy when an object's mass and/or height change: $PE_g = mgh$ • Apply proportional reasoning to the relationship between a spring's potential energy and its deformation, x, according to the equation: $PE_s = \frac{1}{2}kx^2$ • Show that $PE_s =$ area under a graph of Force vs. deformation (stretch or compression), where $F = -kx$. The spring constant k is equal to the slope of the graph and is called the elastic constant. • Analyze conceptually that thermal energy increases when an object's temperature increases. • Apply the idea that energy 	<ul style="list-style-type: none"> • Inquiry Support Lab: Spring Energy Activities

Physics Curriculum Support Document

Goal 6

COMPETENCY GOAL 6: The learner will develop an understanding of energy as the ability to cause change.			
<i>Days</i>	<i>Objective</i>	<i>Content Description</i>	<i>Suggested activities</i>
		<p>can be transferred when objects interact. (See work under 6.02)</p> <ul style="list-style-type: none"> Express and apply the idea that in all situations, energy tends to dissipate throughout the environment. Express the concept of energy conservation by applying the idea that energy can be stored and transferred, but cannot be created or destroyed. Express an understanding of the conservation of energy in words as well as charts, diagrams and graphs. 	
7/180	6.02 Analyze, evaluate, and apply the principle of conservation of energy.	<ul style="list-style-type: none"> Use conceptual analysis and mathematical formulas for energy to determine amounts of energy stored as kinetic energy, elastic potential energy, gravitational potential energy, and amounts of energy transferred through work. Analyze and investigate the relationship among kinetic, potential, and other forms of energy to see that total energy is conserved. (pendulum in various positions, ball in flight, stretching a rubber band, hand generator, turbine) Solve problems relating the amounts of energy stored and transferred applying the principle of conservation of energy. 	
7/180	6.03 Analyze, evaluate, and measure the transfer of energy by a	<ul style="list-style-type: none"> Identify work as the transfer of energy by a force acting through a distance, when that 	

Physics Curriculum Support Document

Goal 6

COMPETENCY GOAL 6: The learner will develop an understanding of energy as the ability to cause change.			
<i>Days</i>	<i>Objective</i>	<i>Content Description</i>	<i>Suggested activities</i>
	force. • Work. • Power.	force acts in the direction of motion of the object: $W = F \Delta x$ <ul style="list-style-type: none"> Recognize that work is equal to the area under a force vs. distance graph. Define power as the rate of transferring energy or the rate of doing work. Use the power equation to solve mathematical problems involving transfer of energy through work: $P = \frac{W}{\Delta t} = F \bar{v}$ Recognize that a force must cause displacement in order for work to be done. 	
6/180	6.04 Design and conduct investigations of: • Mechanical energy. • Power.	<ul style="list-style-type: none"> Verify through investigations the conservation of energy in situations involving transfer of energy among kinetic energy, elastic potential energy and gravitational potential energy. Investigate power. 	

Physics Curriculum Support Document

Goal 7

COMPETENCY GOAL 7: The learner will develop an understanding of wave motion and the wave nature of sound and light.			
<i>Days</i>	<i>Objective</i>	<i>Content Description</i>	<i>Suggested activities</i>
7/180	<p>7.01 Analyze, investigate, and evaluate the relationship among the characteristics of waves:</p> <ul style="list-style-type: none"> • Wavelength. • Frequency. • Period. • Amplitude. 	<ul style="list-style-type: none"> • Design and conduct investigations to measure the basic properties of mechanical waves: amplitude, period, frequency, wavelength and wave speed. • Compare and contrast mechanical and electromagnetic waves. • Understand that waves transport energy, momentum, and information. • Draw and identify the basic characteristics of a transverse wave including: trough, crest, amplitude, frequency, wavelength, and period. • Draw and label the basic characteristics of a longitudinal (compressional) wave including: period, rarefaction, and compression. • Distinguish between mechanical and electromagnetic waves in terms of the medium through which they travel. • Understand that a wave's energy is related to its amplitude. • Apply the inverse relationship between frequency and wavelength at a constant wave speed determined by the medium. • Solve problems relating period, frequency, wavelength and wave speed: $T = \frac{1}{f}$ $v = f\lambda$ • Relate characteristics of 	<ul style="list-style-type: none"> • Slinky demo

Physics Curriculum Support Document

Goal 7

COMPETENCY GOAL 7: The learner will develop an understanding of wave motion and the wave nature of sound and light.			
Days	Objective	Content Description	Suggested activities
		waves to human perceptions of sound - such as pitch, loudness, and timbre.	
4/180	7.02 Describe the behavior of waves in various media.	<ul style="list-style-type: none"> Explain how mechanical waves, such as sound and water waves, are produced by objects vibrating in a medium. Qualitatively relate the speed of sound to the type of medium and its temperature. Show how wave speed can be calculated from a material's index of refraction and the speed of light in a vacuum: $n = \frac{c}{v}$ Observe water waves created by a vibrating object, and explain how the characteristics of the wave change depending on the frequency of the vibrating source. 	<ul style="list-style-type: none"> Inquiry Support Lab: Waves and Springs Activities
7/180	7.03 Analyze the behavior of waves at boundaries between media: <ul style="list-style-type: none"> Reflection, including the Law of Reflection. Refraction, including Snell's Law. 	<ul style="list-style-type: none"> Understand how a wave front reflects from and transmits through a boundary, including the speed of the wave in the new medium. Determine the speed of a wave in a new medium using the equation: $n_1 v_1 = n_2 v_2$. Analyze and apply the Law of Reflection: $\theta_{\text{incidence}} = \theta_{\text{reflection}}$, measured from normal line. Analyze and apply Snell's Law: $n_1 \sin \theta_1 = n_2 \sin \theta_2$, where the angles are measured from the normal Describe and calculate 	<ul style="list-style-type: none"> Inquiry Support Lab: Reflection and Refraction Activities

Physics Curriculum Support Document

Goal 7

COMPETENCY GOAL 7: The learner will develop an understanding of wave motion and the wave nature of sound and light.			
<i>Days</i>	<i>Objective</i>	<i>Content Description</i>	<i>Suggested activities</i>
		<p>critical angles for total internal reflection:</p> $\sin \theta_c = \frac{n_2}{n_1}$ <ul style="list-style-type: none"> Design and conduct investigations measuring angle of reflection, angle of refraction, and critical angle. Determine the relationship among the variables graphically and with equations (see inquiry support lab for this objective). 	
4/180	7.04 Analyze the relationship between the phenomena of interference and the principle of superposition.	<ul style="list-style-type: none"> Explain principle of superposition. Compare and contrast constructive interference and destructive interference. Observe and conceptually analyze interference and superposition in traveling waves (springs, water, sound, light). 	
2/180	7.05 Analyze the frequency and wavelength of sound produced by a moving source (the Doppler Effect).	<ul style="list-style-type: none"> Describe the perceived frequency and wavelength change when a sound source is moving toward or away from an observer. Listen to sound from moving sources and explain how the motion changes the sound. Observe the change in frequency and wavelength of water waves from a moving source. 	<ul style="list-style-type: none"> <u>Inquiry Support Lab: Doppler Effect</u>

Physics Curriculum Support Document

Goal 8

COMPETENCY GOAL 8: The learner will build an understanding of static electricity and direct current electrical circuits.			
<i>Days /180</i>	<i>Objective</i>	<i>Content Description</i>	<i>Suggested activities</i>
7/180	<p>8.01 Analyze the nature of electrical charges.</p> <ul style="list-style-type: none"> Investigate the electrical charging of objects due to transfer of charge. Investigate the conservation of electric charge. Analyze the relationship among force, charge and distance summarized in Coulomb's law. 	<ul style="list-style-type: none"> Conduct investigations involving static electricity. Analyze the nature of electrical charge. <ol style="list-style-type: none"> The two different kinds of electric charge are defined as positive and negative. Like charges repel and unlike charges attract. Understand that matter is neutral when charges are balanced and becomes charged when there is a transfer of electrons. Recognize the three methods of charge transfer are friction, conduction, and induction. Understand that electric charge is conserved (neither created nor destroyed and may be transferred from one object to another). Calculate the electrostatic force between any two point charges using the equation: $F = \frac{kq_1q_2}{d^2}$ Apply the inverse square relationship between the force and the distance between the charges. Apply the proportional relationship between the force and the product of the charges. Cite evidence from experiments to support the existence of two kinds of charge, the neutrality of most 	<ul style="list-style-type: none"> Electrostatic lab-investigating electrostatics using common household items such as making an electroscope from cellophane tape, balloons or pie pans <u>Inquiry Support Lab: Sticky Tape Lab</u>

Physics Curriculum Support Document

Goal 8

COMPETENCY GOAL 8: The learner will build an understanding of static electricity and direct current electrical circuits.			
<i>Days /180</i>	<i>Objective</i>	<i>Content Description</i>	<i>Suggested activities</i>
		matter, and explain charging by friction, conduction and induction.	
9/180	8.02 Analyze and measure the relationship among potential difference, current, and resistance in a direct current circuit.	<ul style="list-style-type: none"> • Develop the concept of a complete circuit. • Develop the concept of current as the rate of flow of charge. Charge is everywhere in the circuit and does not enter or leave it. • Develop the concept of resistance as due to the characteristics of the material. • Understand how electric potential is related to energy. • Recognize that a difference in potential creates current and thus pushes charges around the circuit. • Recognize that energy is required to move charges in a circuit. • Recognize that energy is dissipated by or transferred to other devices such as light bulbs or motors. • Apply Ohm's Law: $V = IR$ <ul style="list-style-type: none"> ○ Solve simple circuit problems. ○ Graph results from investigations. • Observe how potential difference, current and resistance affect the brightness of light bulbs in circuits with batteries. • Design and conduct investigations to measure potential difference and 	<ul style="list-style-type: none"> • Current and resistance lab • <u>Inquiry Support Lab: Circuit Activity</u> • <u>Inquiry Support Lab: Verifying Ohm's Law</u> • <u>Inquiry Support Lab: Ohm's Law Activity</u> • <u>Inquiry Support Lab: Current and Voltage for Resistors in Series, Parallel, and Mixed Circuits</u>

Physics Curriculum Support Document

Goal 8

COMPETENCY GOAL 8: The learner will build an understanding of static electricity and direct current electrical circuits.			
Days /180	Objective	Content Description	Suggested activities
		current in direct current circuits with resistors and batteries.	
9/180	<p>8.03 Analyze and measure the relationship among current, voltage, and resistance in circuits.</p> <ul style="list-style-type: none"> • Series. • Parallel. • Series-parallel combinations. 	<p>Series circuits</p> <ul style="list-style-type: none"> • Recognize that current is the same throughout the circuit: $I_t = I_1 = I_2 = I_3 = \dots$ • Recognize that voltage divides proportionally to the resistance. The sum of the voltage drops across the circuit equals the potential difference supplied to the circuit: $V_t = V_1 + V_2 + V_3 + \dots$ • Calculate equivalent resistance: $R_{eq} = R_1 + R_2 + R_3 + \dots$ • Apply Ohm's law to series circuits. <p>Parallel circuits</p> <ul style="list-style-type: none"> • Recognize that current divides in inverse proportion to the resistance. The sum of the current through each device equals the current supplied to the circuit: $I_t = I_1 + I_2 + I_3 + \dots$ • Recognize that the voltage drop across each branch is the same: $V_t = V_1 = V_2 = V_3 = \dots$ • Calculate equivalent resistance: $\frac{1}{R_{eq}} = \frac{1}{R_1} + \frac{1}{R_2} + \frac{1}{R_3} + \dots$ • Apply Ohm's law to parallel circuits. <p>Combination circuits</p> <ul style="list-style-type: none"> • Calculate equivalent 	

Physics Curriculum Support Document

Goal 8

COMPETENCY GOAL 8: The learner will build an understanding of static electricity and direct current electrical circuits.			
<i>Days /180</i>	<i>Objective</i>	<i>Content Description</i>	<i>Suggested activities</i>
		<p>resistance.</p> <ul style="list-style-type: none"> Develop a conceptual understanding of voltage and current in a combination circuit. <p>Investigations</p> <ul style="list-style-type: none"> Design and conduct investigations of series and parallel circuits, including prediction of voltage and current and testing of these predictions through measurements. 	
2/180	8.04 Analyze and measure the nature of power in an electrical circuit.	<ul style="list-style-type: none"> Develop the concept of power using dimensional analysis (unit cancellation). Apply the power equation: $P = VI = I^2R = \frac{V^2}{R}$ 	<ul style="list-style-type: none"> <u>Inquiry Support Lab: Voltage Activity</u>

Physics Curriculum Support Document

Safety in the Science Classroom and Laboratory

Safety in the Science Classroom and Laboratory

Chemical Management:

In North Carolina, it is the responsibility of the Superintendent of a school system to appoint a qualified chemical hygiene officer to direct the development of and compliance with the chemical hygiene plan for the school system. This plan must include protocols and processes for chemical management for science laboratories and preparation rooms, as well as, professional development for science teachers and administrators. Because laws, codes and standards change, the plan must be reviewed and updated annually or more often as necessary.

Instruction, Supervision, and Maintenance of a Safe Learning Environment:

In North Carolina, it is the teacher's responsibility to address safety in planning instructional activities, laboratory investigations, and to supervise students so that all activities and investigations are carried out in a safe manner. The teacher is responsible for adhering to professional standards, NC laws and codes when assessing the learning environment. Ongoing professional development is an essential part of ensuring laboratory safety.

It is the principal's responsibility to provide personal protective equipment and resources to ensure science teachers can teach the North Carolina's science curriculum safely. All *North Carolina Standard Course of Study* Science classes are designed to be laboratory courses and must include a laboratory component.

The suggestions and resources for science safety and resources included here are in no way comprehensive but may serve as a quick reference for a few common safety issues.

1) Chemicals:

- a. Order only the amounts you will use for one year. Do as much microchemistry as possible to minimize hazards
- b. Be sure you have an appropriate storage system for chemicals.
- c. You must have the MSDS available for all chemicals in your classroom/prep room (including kitchen/grocery store chemicals). You should go over the MSDS information with students each time they will be using a chemical. Document this in your lesson plan book.
- d. Use the smallest amounts and weakest/most dilute concentrations of chemicals that you can and still have a viable investigation/demonstration.
- e. Be sure you have appropriate disposal arranged before using a chemical.
- f. Avoid the use of toxic chemicals.
- g. Sulfur is a common allergen. Reactions that use or produce sulfur compounds should be performed under a working hood.

Physics Curriculum Support Document

Safety in the Science Classroom and Laboratory

Other Resources

American Chemical Society

American Chemical Society Safety Guidelines

Chemical Safety for Teachers and Their Supervisors: Grades 7-12

Safety Audit/Inspection Manual

Teachers can order single copies by calling ACS at 1-800-227-5558.

29 CFR 1910 OSHA

General Industry Regulations

www.oshacfr.com

CRC Handbook of Laboratory Safety

5th edition

A. Keith Furr

www.crcpress.com

2000 Emergency Response Guidebook

U.S. Dept of Transportation

Research and special Programs Administration

<http://hazmat.dot.gov/guidebook.htm>

A Guide to Working With Corrosive Substances

Harry E. Payne, Jr

North Carolina Occupational Safety and Health Standards for General Industry

NC Department of Labor

Division of Occupational Safety and Health

4 West Edenton Street

Raleigh, NC 27601-1092

Handbook of Chemical Health and Safety

Robert J Alalmo editor

Learning by Accident

Edited: Fariba Mojtabai & James Kaufman

Volume # 2

The Laboratory safety Institute

192 Worchester Road

Natick, MA 01760

It's Elementary... and Beyond

www.chemed.org

MSDS Sheets for Chemicals (Material Safety Data Sheets)

Numerous sources – here are some links

www.flinnsci.com/homepage/cindex.html

June 2007

Physics Curriculum Support Document

Safety in the Science Classroom and Laboratory

www.uvm.edu/uvmsafety/labsafety/chemsafety/netmsds.html (grocery/kitchen chemicals)

www.msds.pdc.cornell.edu/msdssrch.asp

www.fishersci.com

www.osha.gov

www.cdc.gov/niosh

National Science Teachers Association www.nsta.org

Click on *Publications* and *Position Statements*.

Numerous NSTA position statements on Safety, Field Trips, Class Size, etc.

NSTA Safety Publications:

Exploring Safely: A Guide for Elementary Teachers- Terry Kwan & Juliana Texley

Inquiring Safely: A Guide for Middle School Teachers- Terry Kwan & Juliana Texley

Investigating Safely: A Guide for High School Teachers- Juliana Texley, Terry Kwan, & John Summers

The OSHA Answer Book (7th edition)

Mark Moran

Right-To Know Pocket Guide for school & University Employees

National Fire Rating System Reference Guide

Lab Safety Supply

PO Box 1368

Janesville, WI 53547-1368

1-800-356-0783

Safetycertified.com

1536 Kingsley Ave

Suite 126

Orange Park, FL 3207

1-800-597-2040

Safety in Academic Chemistry Laboratories

Volume 2

Accident Prevention for Faculty and Administrators 7th ed

(also have student version)

American Chemical Society

1155 16th St, NW

Washington, DC 20036

Safety in the Elementary (K-6) Science Classroom

Second Edition

Committee on Chemical Safety

1155 Sixteenth St, NW

Washington, DC 20036

Chemistry.org

June 2007

Physics Curriculum Support Document

Safety in the Science Classroom and Laboratory

Safety in High School and College Laboratories

Fisher Science Education

1 800 955 1177

1 800 955 0740 (f)

www.fisheredu.com

Science Classroom Safety and the Law

Flinn Scientific Inc.

P.O. Box 219

Batavia, IL60510

E-mail: flinn@flinnsci.com

Website: www.flinnsci.com

Science Laboratory Safety Manual

Linda M. Stroud, Ph.D.

www.sciencesafetyconsulting.com

Other safety resources are available from several science supply catalogs.

Physics Curriculum Support Document
Activities and Labs

Activities and Labs

Physics Curriculum Support Document

Linear Motion: Background Information

Linear Motion

Standard Course of Study Goals and Objectives

Goal 1: The learner will develop abilities necessary to do and understand scientific inquiry.

1.02 Design and conduct scientific investigations to answer questions about the physical world.

- Create testable hypotheses.
- Identify variables.
- Use a control or comparison group when appropriate.
- Select and use appropriate measurement tools.
- Collect and record data.
- Organize data into charts and graphs.
- Analyze and interpret data.
- Communicate findings.

Goal 2: The learner will build an understanding of linear motion.

2.01 Analyze velocity as a rate of change of position:

- Average velocity.
- Instantaneous velocity.

Introduction to the Teacher

Inquiry approach:

Conduct some type lab activity that requires students to measure the **position** of an object moving at a constant velocity **as a function of time**. Possible materials needed to conduct the investigation might be meter sticks and stopwatches, or ticker-tapes attached to the moving object, or motion detectors or range finders, or video analysis of motion, or photogates....any of these could be used to get the **position** of the moving object (such as a bowling ball or battery-operated toy car or truck that moves uniformly) **at various instants in time**.

The location of the object (establish a frame of reference, assign a positive value to indicate motion in one direction and a negative value to indicate motion in the opposite direction) should be recorded at various clock readings during its motion and a position vs. elapsed time graph should be plotted. The idea is to generate a position vs. time graph that is linear, construct the best line fit to the data, and develop the concept that the magnitude of the slope of the line represents the speed while the direction of the line (positive or negative slope) represents the vector nature of the motion (toward or away from a reference point) (Goal 2.02). From the equation of the line of best fit drawn to the data graphed, the basic equation for constant velocity is generated:

$$\text{position} = \text{average velocity} * \text{elapsed time} + \text{initial position}$$

where position is the variable plotted on the y-axis, elapsed time is the variable plotted on the x axis, average velocity (the change in position divided by the time required to make that change) is the slope of the line, and initial position is the y-intercept. From the formula list for the EOC, this will appear as $\Delta s = v\Delta t$ where Δs (the displacement) is position - initial position, v is the average velocity and Δt is the elapsed time.

Physics Curriculum Support Document

Linear Motion: Background Information

Students should be encouraged to develop a definition for constant velocity once they have completed the activity and recognize that a position vs. time graph will be linear for objects moving with a constant velocity. They should be able to determine the magnitude of the velocity from the slope of the graph and determine the direction of movement toward or away from a reference point by the sign of the slope (positive slope means moving away from the reference point and negative means moving toward the reference point).

Safety Considerations

If meter sticks are used to measure the position of the moving object, students should not use them as “swords”.

References

This activity was created by Patty Blanton (Watauga County Public Schools, Boone, NC).

- Modeling High School Physics website, Teacher notes for unit 2
http://modeling.asu.edu/Modeling-pub/Mechanics_curriculum/2-Constant%20v/01_U2%20Teachernotes.pdf
- Straight line motion in two parts- use part A for this goal
<http://www.iit.edu/~smile/ph9701.html>
- Motion of a bowling ball- an inquiry approach
<http://www.iit.edu/~smile/ph96m5.html>
- Straight line motion with a Stomper car Parts 1 and 2- uses ticker-tape timing
<http://www.iit.edu/~smile/ph93ab.html>

Physics Curriculum Support Document

Linear Motion: Laboratory

Linear Motion

Purpose

To determine the relationship between the position and time of a moving object

Materials

- A uniformly moving object such as a battery driven car or a bowling ball
- Meter stick or some other tool to measure position of the moving object
- Stopwatch or some method to determine the clock reading when the position is measured

Introduction to Student

After some initial observations of the moving object, you will attempt to determine whether the motion is uniform (does the position change by the same amount during equal time intervals?)

Procedure

Determine the location from which all position measurements will be made. Decide how you will measure the change in position with respect to time as the object moves. Record the position of the object for at least 5 instants in time as the object moves. Plot the position vs. time for these measurements. Determine if the shape of the resulting graph suggests a relationship between the variables plotted. Can you fit a line to the data and determine the equation for the line in terms of the variables plotted. Be prepared to discuss your analysis with the class.

Extensions

- How would the shape of the graph change if you started the same object at some point away from the starting point used in the lab and let the object move toward that starting point?
- If you have two objects moving uniformly toward each other, how could you graphically determine the point where they would meet? Check this prediction mathematically and then validate your prediction experimentally.

Physics Curriculum Support Document

Motion on an Inclined Surface: Background Information

Motion on an Inclined Surface

Standard Course of Study Goals and Objectives

Goal 1: The learner will develop abilities necessary to do and understand scientific inquiry.

1.03 Formulate and revise scientific explanations and models using logic and evidence to:

- Explain observations.
- Make inferences and predictions.
- Explain the relationship between evidence and explanation.

Goal 2: The learner will build an understanding of linear motion.

2.01 Analyze velocity as a rate of change of position:

- Average velocity.
- Instantaneous velocity.

2.03 Analyze acceleration as rate of change in velocity.

2.04 Using graphical and mathematical tools, design and conduct investigations of linear motion and the relationships among:

- Position.
- Average velocity.
- Instantaneous velocity
- Acceleration.
- Time.

Nature of science and science as inquiry strands:

Students will observe an object moving with constant acceleration, determine what is changing as the object moves (position and time), determine the measurements needed to determine the relationship between the variables, design and conduct an experiment to collect the data, graphically analyze the data, draw conclusions and share results with classmates. They will support their conclusions with evidence. There should be opportunities for multiple representations (graphical, mathematical, verbal, and diagrammatic) to express understanding. They should be given opportunities to test their ideas and apply the models that have been developed.

Science and technology strand:

Data to develop this strand can be collected using low-tech instruments such as meter sticks for distance measurements and stopwatches or seconds pendulum for timing, medium tech with ticker tape timers, or higher tech such as motion detectors, range finders, photogates, or video analysis. The analysis of the data can be done using graph paper or graphing calculators, spreadsheets, or even graphical analysis programs.

Physics Curriculum Support Document

Motion on an Inclined Surface: Background Information

Introduction to the Teacher

Conduct some type lab activity that requires students to measure the position of an object moving at a constant acceleration as a function of time.

Materials should include:

- Meter sticks and stopwatches, or ticker tapes attached to the moving object, or motion detectors or range finders, or video analysis of motion, or photogates.
- A ball bearing or some other ball or low-friction cart to roll down an inclined surface.

Begin the observations of the object by releasing it from rest and allowing it to move down a smooth inclined surface. The location of the object should be recorded at various clock readings during its motion and a position vs. elapsed time graph should be plotted. The idea is to generate a position vs. time graph that is parabolic in shape (let the position at time = 0 be zero and let the direction of the motion be positive). Discuss ways to try to manipulate the data so that the graph is linear. Have students try the combinations they think will produce a linear relationship. . . . position vs. time squared should be linear if the object is accelerating at a constant rate. Although the slope of the line has units of acceleration, its mathematical value is actually one-half the acceleration. To help students develop this concept, have them construct lines tangent to the curve of the original position vs. time graph.

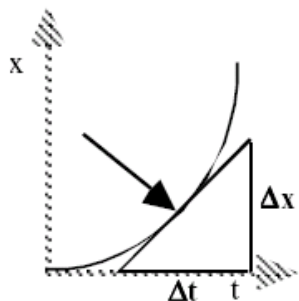

The slope of these tangent lines represents the instantaneous velocity at the point where each line is drawn*. After determining the instantaneous velocity at several points in time, construct a velocity vs. time graph. Again, if this object is accelerating at a constant rate, the resulting graph should be linear and the slope of the graph represents the rate at which the velocity is changing (the acceleration). Compare this value to the slope of the position vs. time squared graph generated earlier.

Physics Curriculum Support Document

Motion on an Inclined Surface: Background Information

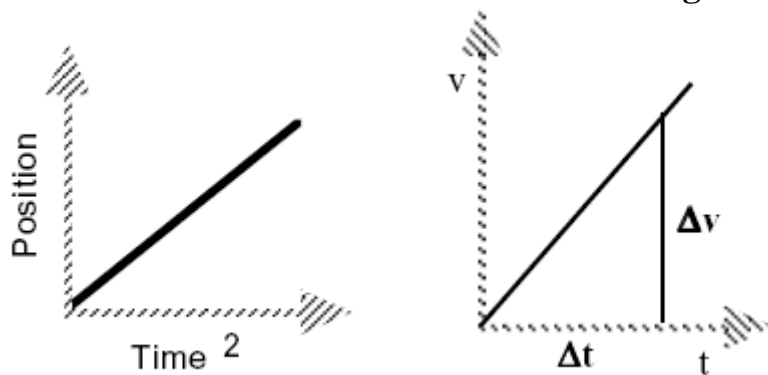

The slope of this graph should be acceleration because it represents the rate at which the velocity changed. Let this definition for acceleration come from this analysis of the graph. It should be twice the value of the slope from the position vs. time squared graph. Choose a particular time interval and determine the value for the area under the curve for the velocity vs. time graph. This should represent the displacement of the object during this same interval. The kinematic equations for motion can be derived once these relationships are developed. For a very good description of deriving the kinematic equations, visit this website <http://physicsclassroom.com/Class/1DKin/U1L4a.html> and <http://physicsclassroom.com/Class/1DKin/U1L6a.html>

*If you are working with graphing calculators, this is a great place to use them to get slopes of lines tangent to the curve. For a detailed description of doing it with TI calculators, go to http://modeling.asu.edu/Modeling-pub/Mechanics_curriculum/3-Uniform%20a/03_slope-TI.pdf. This could also be done using the Vernier software program called Graphical Analysis and using the Analyze, Tangent feature.

Give students plenty of practice analyzing various graphical representations of accelerated motion. One example can be found at http://modeling.asu.edu/Modeling-pub/Mechanics_curriculum/3-Uniform%20a/05_U3%20kincurves.pdf. Also the website for the physics classroom has many examples that students can use interactively. Another excellent computer program is Graphs and Tracks from Physics Academic Software (approximately \$350 for a site license).

http://www.webassign.net/pasnew/graphs_and_tracks/gandt.html. An online version of Graphs and Tracks called RollBall can be found at <http://dept.physics.upenn.edu/courses/gladney/mathphys/java/sect2/RollBall.html>

Safety Considerations

If using PASCO carts, take care to keep the carts from rolling off and hitting the floor.

References

- The Physics Classrooms website
<http://physicsclassroom.com/Class/1DKin/U1L4a.html>
<http://physicsclassroom.com/Class/1DKin/U1L6a.html>
- Modeling High School Physics Curriculum materials
- http://modeling.asu.edu/Modeling-pub/Mechanics_curriculum/3-Uniform%20a/

Physics Curriculum Support Document

Motion on an Inclined Surface: Background Information

- Teachernotes.pdf (see Post lab discussion for the development of the kinematic equations from the graphs) and slope-TI.pdf documents
- http://modeling.asu.edu/Modeling-pub/Mechanics_curriculum/3-Uniform%20a/05_U3%20kincurves.pdf for a worksheet comparing position, velocity and acceleration vs. time graphs for the same motion.

Physics Curriculum Support Document

Motion on an Inclined Surface: Laboratory

Motion on an Inclined Surface

Purpose

To determine the relationship between the position and time of a object moving down an inclined surface

Materials

- Meter sticks and stopwatches, or ticker tapes attached to the moving object, or motion detectors or range finders, or video analysis of motion, or photogates.
- A ball bearing or some other ball or low-friction cart to roll down an inclined surface.

Introduction to Student

In the previous investigation, you examined an object moving at a constant velocity across a horizontal surface and found that the position changed uniformly with respect to time. The graph of position vs. time was linear and from it you found the velocity of the object and the equation for the motion. In this investigation you are to do a similar study of an object released from rest at the top of an inclined plane.

Procedure

1. Release an object from rest at the top in an inclined surface and allow it to roll down the incline.
2. Determine the position at various instants in time as you did in the last investigation.
3. Plot a position vs. time graph of your data.

Lab Data

Position (m)	Time (s)

Questions to Guide Analysis

1. How does the shape of this graph compare to the one for constant velocity you generated in the last investigation?
2. Try manipulating one or both variables to see if you can find any combination that will yield a linear relationship. For example, try either squaring or taking the

Physics Curriculum Support Document

Motion on an Inclined Surface: Laboratory

- square root of time and plotting the graph again (position vs. time squared or position vs. square root of time). Find the equation for the best line fit of the data
- Using the original position vs. time graph, draw lines tangent to the curve for at least 5 instants in time. The slope of a tangent line should represent the velocity the object had at that instant (referred to as the instantaneous velocity). Plot another graph of the instantaneous velocity vs. time. Is this graph linear? Determine the slope of the best-fit line and describe in words what that slope means. How does the slope from this graph compare with the one you plotted for step 2?
 - Choose two points on the instantaneous velocity vs. time graph and find the area under the curve between those two points. What would be the units of that area? What do you think this quantity represents? Can you verify that from your first graph (position vs. time)?

Physics Curriculum Support Document

Projectile Motion: Background Information

Projectile Motion

Standard Course of Study Goals and Objectives

GOAL 1: The learner will develop abilities necessary to do and understand scientific inquiry.

1.02 Design and conduct scientific investigations to answer questions about the physical world.

- Create testable hypotheses.
- Identify variables.
- Use a control or comparison group when appropriate.
- Select and use appropriate measurement tools.
- Collect and record data.
- Organize data into charts and graphs.
- Analyze and interpret data.
- Communicate findings.

GOAL 3: The learner will build an understanding of two-dimensional motion including circular motion.

3.02 Design and conduct investigations of two-dimensional motion of objects.

3.03 Analyze and evaluate independence of the vector components of projectile motion.

Introduction to the Teacher

What Students should know after the lesson:

Students will analyze the motion of a basketball free-throw shot to identify the motion and forces acting on the ball. Using a videotaped image of the shot and frame-by-frame analysis of the motion, students will look at the position of the ball in the vertical direction and in the horizontal direction. Using graphs of position vs. time in each direction, they will determine the type of motion and associate this motion with the models previously identified (constant velocity or constant force).

Materials

Materials will vary depending on the method you choose to determine the position of the ball as it changes over time. These instructions are written for video analysis of the motion. The program used is Scion, a PC program that can be downloaded for free from the Internet from Scion Corporation. A similar program is also available for Mac from NIH image. For Scion, the frames must be captured and saved as TIFF files. The image I used was a file called Basketball stack downloaded from the CIPE Program but you could video tape your own students to analyze. Another option would be to use programs for video capture such as Videograph and Videograb for Mac or World in Motion for PC. A third option would be to take measurements from a strobe photograph of a projectile (one such picture of a stream of water is in the Merrill textbook; another can be found at <http://www-personal.umich.edu/~jlhoffmn/physics/clpromo4.htm>).

These pictures can be scanned to digitize or downloaded to get them into a format that can be opened in Scion Image. A spreadsheet program such as Microsoft Excel can be

Physics Curriculum Support Document

Projectile Motion: Background Information

used to organize and graph the data. This could also be done manually or with a graphing calculator or a graphing program such as Graphical Analysis.

Procedure

Begin by tossing a ball between two people and have the students observe the motion. Ask them to sketch the location of the ball at 5 different points in its path. Have them use arrows to represent the horizontal velocity and the vertical velocity at each point. In a separate drawing of the same 5 points, have them represent with arrows the forces that are acting on the object. The next step is to collect data from the videotaped motion of a basketball or from a scanned or downloaded picture of an object undergoing projectile motion.

1. One option would be to put an acetate sheet on the monitor screen, and step the video forward at equal time intervals. Mark the position of the ball at each selected frame. When you have at least 6 points marked, take the acetate sheet off the screen and decide how to represent the horizontal and vertical positions at each frame position. Record the horizontal position, vertical position, and time for each marked spot.
2. Another would be to digitize the motion and create a stack of several successive images. This stack can be opened in Scion Image and each slide (called a slice) can be viewed separately. In the Info window, the location of the cursor in pixels is displayed for the X and Y position. Put the cursor on the center of the ball and record the X and Y positions for that slice. Now to the next image (slice) and repeat the measurement for the new position of the ball. Continue for each image (slice) in your stack.
3. Organize these measurements in a spreadsheet. Create a column for time in seconds, a second column for X position in pixels, a third column to repeat the time, and a fourth column for Y position. Record data collected from the video analysis. Highlight the first two columns, choose the chart wizard, create an XY scatter plot with lines connected, label the graph with title and names for each axis, and adjust the scale to accommodate the data. The resulting data should be linear because the object is not accelerating in the X direction. Repeat this with the time (3rd column) and the Y position (4th column). This time the graph will be curved because the object should be accelerating in the Y direction.
4. Have students revisit their original drawings to see if their data matches and supports their predictions. For velocity, each point should have arrows of equal length representing the horizontal velocity and should become shorter in the vertical direction as the object rises and become longer as it falls back toward the ground. For force there should be only one arrow in the vertical direction because of the force exerted by gravity. Students should be encouraged to discuss their interpretation of the graphs and any revisions they make to their original drawings. Students should discuss whether the graphs allow you to determine the actual velocity of the object or a representation of velocity? (Again this will be determined by whether you were able to get data for actual position and time from your method of analysis of your data.)

Physics Curriculum Support Document

Projectile Motion: Background Information

Extensions

A good extension for this activity can be found at the Physics Multimedia Classroom called the Monkey and the Zookeeper. This Gif animation lets students examine several different conditions to test their understanding of projectile motion.

Physics Curriculum Support Document

Centripetal Force: Background Information

Centripetal Force

Standard Course of Study Goals and Objectives

Goal 1: The learner will develop abilities necessary to do and understand scientific inquiry.

1.03 Formulate and revise scientific explanations and models using logic and evidence to:

- Explain observations.
- Make inferences and predictions.
- Explain the relationship between evidence and explanation.

GOAL 3: The learner will build an understanding of two-dimensional motion including circular motion.

3.06 Investigate, evaluate and analyze the relationship among:

- Centripetal force.
- Centripetal acceleration.
- Mass.
- Velocity.
- Radius.

Materials

- 15 to 20 cm length of surgical tubing or glass tubing and string
- Stopwatch
- Meter stick
- Balance
- Graphical Analysis, graphing calculators, other graphing programs or graph paper
- Suspended masses - increments should be in the 30-50 gram range
- Orbiting masses - suggest a number 5 or 6 stopper

Introduction to the Teacher

The object is accelerating because a force, directed toward the center of the circular path, causes the direction of the object of change. The force is directly proportional to the mass and the velocity squared and is inversely proportional to the radius of the circular path.

The rubber stoppers are attached to the end on the string and will provide the object that will be moving in a circular path. The string is threaded through the tubing and masses are suspended at the other end. The tubing is held vertically and the hand is moved in a small circle to start the stopper moving in as close to a horizontal circle as possible. Ask students to describe what they observe about the motion of the stoppers. Ask students what factors they think will cause that motion to change. Among their answers should mass of the stoppers, mass suspended at the end of the

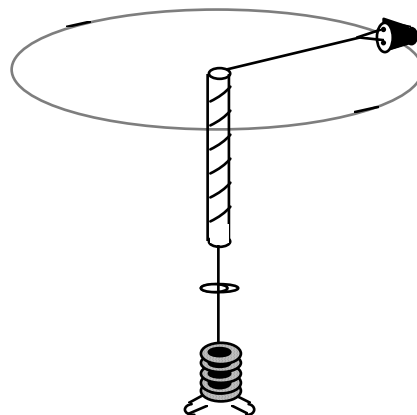

Physics Curriculum Support Document

Centripetal Force: Background Information

string, and radius of the string. Changes in each of these should change the magnitude of the velocity of the stoppers as they move in a circular path. Ask students what they would have to measure to be able to determine the magnitude of the velocity of the stoppers (Need radius of the circle to determine the circumference and the time for one complete circle). The relationships you want them to identify are those between applied force and velocity of the stoppers as they move in the circular path, mass and velocity of the stoppers, and velocity and radius of the circular path. Graphing the results should yield a direct relationship between velocity squared and mass, velocity squared and force squared, and velocity squared and the inverse of mass. Initial graphs should be similar to these:

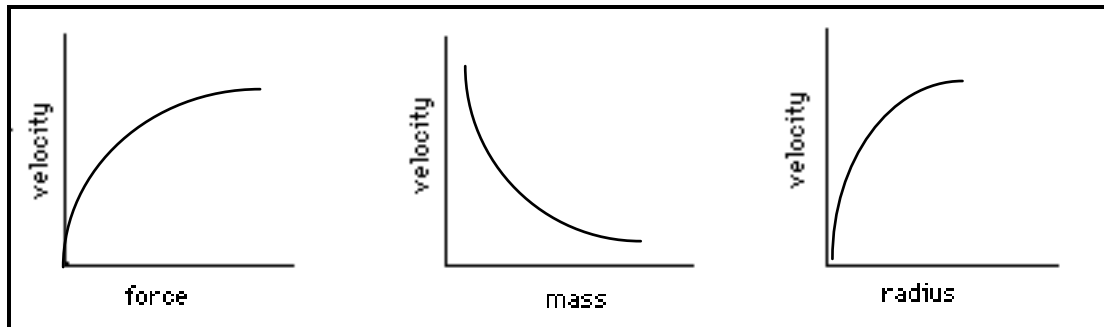

Linearized graphs should be similar to these:

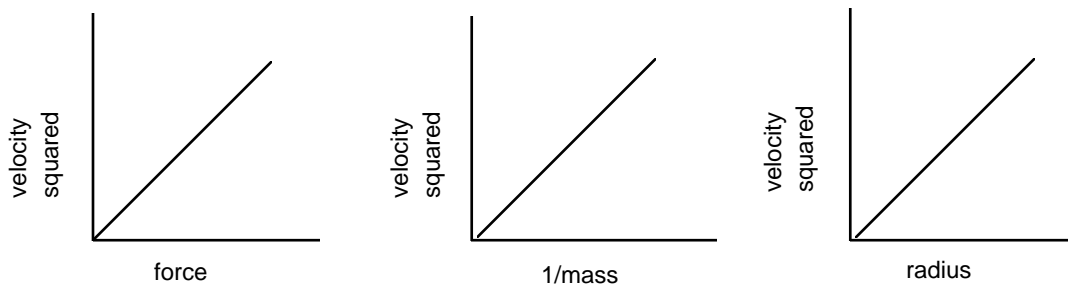

Notes: Make sure there is plenty of room between groups and that safety is emphasized. If the string breaks, the stoppers will fly off tangent to the circular path in which they were moving, making it difficult to predict where they will go.

A spring scale or force probe can be substituted for the hanging masses to get the applied centripetal force. If hanging masses are used, their weight in Newtons provides the centripetal force.

Counting the number of rotations the stoppers make in a given time period is the easiest way to get the time measurement to calculate the velocity. The distance traveled during this time period is the number of circumferences the stoppers moved through. The length of the string from the center of mass of the stoppers to the top end of the tubing is the radius of the circular path.

If students are careful experimenters, you can get good results with this method. If they do not pay attention to details and try to control all the variables except the ones being tested, the results may not be satisfactory.

Physics Curriculum Support Document

Components of Force Vectors: Background Information

A MINILAB – COMPONENTS OF FORCE VECTORS

Standard Course of Study Goals and Objectives

GOAL 1: The learner will develop abilities necessary to do and understand scientific inquiry.

1.03 Formulate and revise scientific explanations and models using logic and evidence to:

- Explain observations.
- Make inferences and predictions.
- Explain the relationship between evidence and explanation.

GOAL 4: The learner will develop an understanding of forces and Newton's Laws of Motion.

4.01 Determine that an object will continue in its state of motion unless acted upon by a net outside force (Newton's First Law of Motion, The Law of Inertia).

4.02 Assess, measure and calculate the conditions required to maintain a body in a state of static equilibrium.

Introduction to the Teacher

This lab is a simple exploration of the relationship between vectors used to hang an object. Students should readily see real-world applications of this activity: hanging heavy objects, etc.

Safety Considerations

Be sure to use sturdy supports for the hanging weight.

References

This activity was adapted from *Physics: Principles and Problems-Glencoe* and was modified by Jane Kinney (Mecklenburg County Public Schools, Charlotte, NC).

Physics Curriculum Support Document

Components of Force Vectors: Laboratory

A MINILAB – COMPONENTS OF FORCE VECTORS

Purpose

This activity will explore the relationship between two force vectors and a weight in equilibrium.

Materials

- Two identical spring scales
- Protractor
- Support system for hanging
- String
- A 500 g mass

Introduction to Student

Hanging heavy objects with two supporting strands is a common problem for engineers and homeowners. Investigate the relationship between the angle between the two strings and the force reading on the scales as you change the angle between the strings.

Procedure

1. Cut two pieces of string, one 40 cm long and the other 10 cm long. At the 20-cm mark on the long string, tie the short string. Make a loop on the other end of the short string.
2. Make loops at the ends of the long string. Slide the spring scales over the support bar (or attach with more string) and hang the ends of the long string from the scales.
3. Hang the 500-g mass from the loop at the bottom of the short string. The two scales should read about the same and the weight should be suspended from the center of the long string in a 'V' shape.
4. Explore the relationship between the angle of the strings and the tension in the strings. Make a data table and record your results.

Lab Data

See above

Questions to Guide Analysis

1. How does changing the angle affect the force on each string?
2. For what angle of the strings were the forces on the strings the least? The greatest? The same as the suspended weight?
3. How can the arithmetic sum of the two forces be greater than the suspended weight?
4. Devise a graph of this data to illustrate your findings.
5. Give some practical applications of this study.

Physics Curriculum Support Document

Newton's Second Law: Background Information

Newton's Second Law

Standard Course of Study Goals and Objectives

GOAL 1: The learner will develop abilities necessary to do and understand scientific inquiry.

1.02 Design and conduct scientific investigations to answer questions about the physical world.

- Create testable hypotheses.
- Identify variables.
- Use a control or comparison group when appropriate.
- Select and use appropriate measurement tools.
- Collect and record data.
- Organize data into charts and graphs.
- Analyze and interpret data.
- Communicate findings.

GOAL 4: The learner will develop an understanding of forces and Newton's Laws of Motion.

4.03 Assess, measure, and calculate the relationship among the force acting on a body, the mass of the body, and the nature of the acceleration produced (Newton's Second Law of Motion).

Introduction to the Teacher

It takes an entire 90-minute period. It tests the engineering skills of the students and the tolerance of the teacher to crashes and bangs! If timers are not available stopwatches work just as well.

Safety Considerations

Things will fall, so expect noise.

References

This activity was adapted from *Modern Physics* and was modified by Jane Kinney (Mecklenburg County Public Schools, Charlotte, NC).

Physics Curriculum Support Document

Newton's Second Law: Laboratory

Newton's Second Law

Purpose

The purpose of the activity is to verify Newton's second law of motion. A cart will be attached to a ticker-tape timer and the relationships between force and acceleration, and mass and acceleration will be investigated.

Materials

- Ticker-tape timer
- Dynamics cart
- String
- Meter stick
- Set of masses
- Triple-beam balance
- Washers
- Pulley with table clamp (optional)

Procedure

Part One

1. Set up the apparatus as shown in the picture below. The timing tape is fastened to one end of the cart and the string is fastened to the other end. The length of the string should be about equal to the height of your lab table.
2. Measure the mass of the cart on the balance and record. Then load the cart with 600 grams of masses. (Do NOT use your 500-gram mass to do this.) Add 600 grams to the mass of your cart and record in Data Table #1 under the column "total mass" for trials 1-4.
3. Pass the string over the pulley or edge of the table and fasten a paper clip to the end of the string. Hang a washer from the paper clip and give the cart a slight push. If the cart moves uniformly, you are ready to go. If the cart will not move, add another washer and try again. The cart should not accelerate, but should move slowly and uniformly. This weight will offset the slight force of friction acting on the cart. Do not remove the washer(s) from the string.
4. You now have 600 grams of mass on the cart. Remove a 100-gram mass from the cart and hang it from the washer. LEAVE ALL OTHER MASS ON THE CART! Hold the cart in place and attach the timer tape to the cart. Start the timer and release the cart. Stop the cart when the mass hits the floor and then stop the timer. Remove the tape and label it "100-gram trial."
5. For the next trial, add a 50-gram mass to the 100-gram mass and repeat the timing. Label this tape "150-gram trial."
6. Return both masses to the cart and remove a 200-gram mass. Hang it from the washer and repeat the timing. Label this tape with "200-gram trial." Add another for a 250-gram trial. Be sure all tapes are labeled.

Physics Curriculum Support Document

Newton's Second Law: Laboratory

Part Two

1. For this part of the lab activity, the falling mass will remain constant at 200 grams. Place a 200-gram mass on the washer and do not add anything else to the string for all trials.
2. Trial 5 is the empty cart (mass previously recorded). Be sure to label the tape. Record this mass under the "total mass" column for trial 5.
3. For trial 6 add 200 extra grams to the cart. For trial 7 add 300 grams and for trial 8 add 400 extra grams. Be sure to carefully label each tape. Add these masses to the mass of the cart for the total mass in trials 6-8.

Lab Data

Mass of the cart _____ add weights _____ Period of the timer _____

DATA TABLE

Trial	Total mass (kg)	Falling Mass (kg)	Number of Dots	Distance (m)
1				
2				
3				
4				
5		0.200		
6		0.200		
7		0.200		
8		0.200		

1. Determine the beginning and end of the dots on each tape. Count the number of dots on each tape and measure the distance between the first and last dots you counted. Record the number of dots and the distance for each tape in your data table.
2. Calculate the total time by multiplying the period of the timer by the total number of dots on each tape. Record in your calculations table.
3. Calculate the gravitational force acting on the falling mass.
($F = \text{mass} \times 9.8 \text{ m/s}^2$) Record.
4. Calculate and record the acceleration using the formula
 $d = \frac{1}{2} a t^2$.

Physics Curriculum Support Document

Newton's Second Law: Laboratory

CALCULATIONS TABLE

Trial	Total time (s)	Gravitational force (N)	Acceleration (m/s^2)
1			
2			
3			
4			
5		1.96	
6		1.96	
7		1.96	
8		1.96	

Graphs

1. Graph the data for trials 1-4 on a graph using acceleration on the x-axis and accelerating force on the y-axis. Draw a best-fit line
2. Graph the data for trials 5-8 on a second graph using total mass on the x-axis and acceleration on the y-axis. Draw a best-fit CURVE.

Questions to Guide Analysis

1. What is the significance of the shape of each graph? How do the graphs verify Newton's second law?
2. What evidence is there that the cart was accelerating during each trial?
3. What is the significance of the SLOPE of the force vs. acceleration graph? (Don't miss this one! Figure this out!)
4. What might the y-intercept of the force vs. acceleration graph represent?
5. In what way is the motion of a freely falling object different from the motion of these carts?

Physics Curriculum Support Document

Newton's Second Law-An Inquiry Approach: Background Information

Newton's Second Law – An Inquiry Approach

Standard Course of Study Goals and Objectives

GOAL 1: The learner will develop abilities necessary to do and understand scientific inquiry.

1.03 Formulate and revise scientific explanations and models using logic and evidence to:

- Explain observations.
- Make inferences and predictions.
- Explain the relationship between evidence and explanation.

GOAL 4: The learner will develop an understanding of forces and Newton's Laws of Motion.

4.03 Assess, measure, and calculate the relationship among the force acting on a body, the mass of the body, and the nature of the acceleration produced (Newton's Second Law of Motion).

Introduction to the Teacher

This is a totally different approach to Newton's second law. This is the modeling approach and the student himself must make decisions about what to measure and what to graph. There are numerous problems to be worked out and the lab may take more time than the traditional approach.

Materials

- Wheeled carts, dynamics carts, or glider
- Wood ramps, PASCO tracks, or air tracks
- Photogates w/ appropriate interface: ULI Timer, Logger Pro, or Data Studio software
- Pulleys with clamps
- Graphical Analysis
- Balance for mass measurement
- Spring scales (Newton calibration)
- Hangers for slotted weights (or equivalent)

Lab Discussion

- Allow a suspended mass to tow a cart (glider) across the track; ask students to observe its motion. We've already established that a force is required to produce an acceleration. We just haven't quantified the relationship. Rather than brainstorming general observations, ask them to identify other factors that might affect the acceleration of the cart. To proceed, the list must include mass, amount of friction, and amount of force used to tow cart.
- Ask them for ideas on how to minimize the effect of friction. After some discussion, they will hopefully come to the idea of inclining the ramp slightly to compensate for friction.

Physics Curriculum Support Document

Newton's Second Law-An Inquiry Approach: Background Information

- Ask them how to measure the acceleration of the cart. While they cannot measure it directly, there are at least two ways to determine the acceleration. One can calculate it from rearrangement of the kinematical model: $x_f = x_i + v_i t + \frac{1}{2} a t^2$.

(Note: The use of this model requires the assumption that acceleration is constant. The rationale for such an assumption could be based on an "extra credit" lab.) Another method is to allow a picket fence affixed to the cart to pass through a photogate. The slope of the velocity vs. time graph yields the acceleration.

- The dependent variable is the acceleration of the cart.
- The independent variables are the mass of the cart/hanger system and the force used to pull the cart.
- Make sure to stress that the mass that is being accelerated is the total mass of the system (the cart and hanging mass are connected, so must accelerate at the same rate).

Lab Performance Notes

- Use small mass hangers (e.g. 5g) and change by 10 to 20g increments.
- Increase cart mass by 0.2 - 0.5 kg increments.
- Adjust the angle of incline so that the cart can move at a constant speed with a very small initial push.
- Convince students that they must transfer mass from the cart to the hanger in order to keep the total mass constant when they vary the force.
- Convert the hanging mass to Newtons.

Safety Considerations

Minimal-expect some crashes and bangs.

References

This activity was developed by Jane Kinney (Mecklenburg County Public Schools, Charlotte, NC).

Physics Curriculum Support Document

Modified Atwood's Machine: Background Information

Modified Atwood's Machine

Standard Course of Study Goals and Objectives

GOAL 1: The learner will develop abilities necessary to do and understand scientific inquiry.

1.03 Formulate and revise scientific explanations and models using logic and evidence to:

- Explain observations.
- Make inferences and predictions.
- Explain the relationship between evidence and explanation.

GOAL 4: The learner will develop an understanding of forces and Newton's Laws of Motion.

4.03 Assess, measure, and calculate the relationship among the force acting on a body, the mass of the body, and the nature of the acceleration produced (Newton's Second Law of Motion).

Introduction to the Teacher

This modeling approach to Newton's second law requires the student himself to make decisions about what to measure and what to graph. There are numerous problems to be worked out and the lab may take more time than the traditional approach.

Materials

- Wheeled carts, dynamics carts, or glider
- Wood ramps, PASCO tracks, or air tracks
- Photogates w/ appropriate interface: ULI Timer, Logger Pro, or Data Studio software
- Pulleys with clamps
- Graphical Analysis
- Balance for mass measurement
- Spring scales (Newton calibration)
- Hangers for slotted weights (or equivalent)

Lab Discussion

- Allow a suspended mass to tow a cart (glider) across the track; ask students to observe its motion. We've already established that a force is required to produce an acceleration. We just haven't quantified the relationship. Rather than brainstorming general observations, ask them to identify other factors that might affect the acceleration of the cart. To proceed, the list must include mass, amount of friction, and amount of force used to tow cart.
- Ask them for ideas on how to minimize the effect of friction. After some discussion, they will hopefully come to the idea of inclining the ramp slightly to compensate for friction.
- Ask them how to measure the acceleration of the cart. While they cannot measure it directly, there are at least two ways to determine the acceleration. One can

Physics Curriculum Support Document

Modified Atwood's Machine: Background Information

calculate it from rearrangement of the kinematical model $x_f = x_i + v_i t + \frac{1}{2} a t^2$.

(Note: The use of this model requires the assumption that acceleration is constant. The rationale for such an assumption could be based on an "extra credit" lab.)

Another method is to allow a picket fence affixed to the cart to pass through a photogate. The slope of the velocity vs. time graph yields the acceleration.

- The dependent variable is the acceleration of the cart.
- The independent variables are the mass of the cart/hanger system and the force used to pull the cart.
- Make sure to stress that the mass that is being accelerated is the total mass of the system (the cart and hanging mass are connected, so must accelerate at the same rate).

Lab Performance Notes

- Use small mass hangers (e.g. 5g) and change by 10 to 20g increments.
- Increase cart mass by 0.2 - 0.5 kg increments.
- Adjust the angle of incline so that the cart can move at a constant speed with a very small initial push.
- Convince students that they must transfer mass from the cart to the hanger in order to keep the total mass constant when they vary the force.
- Convert the hanging mass to Newtons.
- See sample graphs in Figures 1, 2, and 3.

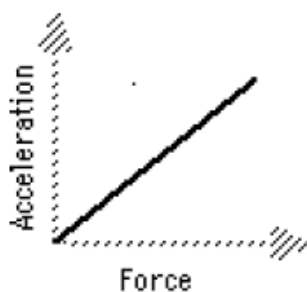

Figure 1

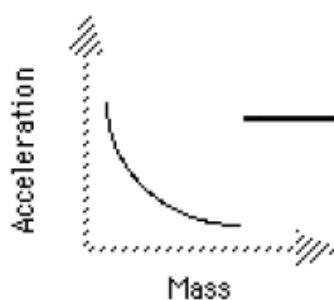

Figure 2

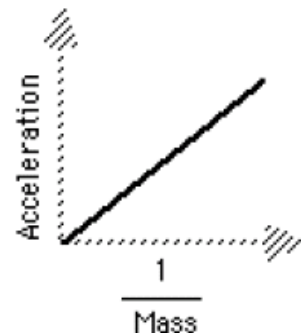

Figure 3

Post-Lab Discussion

- Since the units of slope are not intuitive, focus on proportionalities.
- Discuss the combination of two proportionalities into one:
 $A \propto F$ from Figure 1, $A \propto 1/M$ as shown in the linearization of graph 2 into graph 3
- Turn the proportionality into an equation; rearrange to solve for k .
 $A = k_1 F$, $A = k_2 / M$, $A = k_1 k_2 F / M$, $k_1 k_2 = k$
- Substitute values for k_1 from regression line for graph 1 and for k_2 from regression line for graph 3 to solve for k . With luck, students' values should cluster around 1.0. Now is the time to point out that the slope of force of gravity vs. mass (9.8

Physics Curriculum Support Document

Modified Atwood's Machine: Background Information

N/kg) and the slope of velocity vs. time (9.8 m/s^2) have the same numerical value due to the way the Newton was defined.

Safety Considerations

Minimal-expect some crashes and bangs.

References

This activity was developed by Jane Kinney (Mecklenburg County Public Schools, Charlotte, NC).

Physics Curriculum Support Document

Weight vs. Mass: Background Information

Weight vs. Mass

Standard Course of Study Goals and Objectives

Goal 1: The learner will develop abilities necessary to do and understand scientific inquiry.

1.02 Design and conduct scientific investigations to answer questions about the physical world.

- Create testable hypotheses.
- Identify variables.
- Use a control or comparison group when appropriate.
- Select and use appropriate measurement tools.
- Collect and record data.
- Organize data into charts and graphs.
- Analyze and interpret data.
- Communicate findings.

GOAL 4: The learner will develop an understanding of forces and Newton's Laws of Motion.

4.07 Assess and calculate the nature and magnitude of gravitational forces (Newton's Law of Universal Gravitation).

Materials

- Spring scale or force probe and some place to attach it so it hangs vertically (scale should be calibrated in Newtons)
- Mass hanger and lab masses sufficient to allow 6 data pairs (things such as cups of sand or other unknown masses may be used and massed on a balance)

Introduction to the Teacher

Students will know that the force that gravity exerts on an object is directly proportional to the mass and that the gravitational field strength is approximately 9.8 N/kg. They will be introduced to the concept that the weight is the force that gravity exerts on the object.

Drop a standard mass onto a soft surface and ask the students to identify the force(s) acting on the object. Most will say "Gravity". Have them identify the characteristics of the object that might influence the force that gravity has on the object. Which of these can be measured? Most will identify mass as the main characteristic that will change the force that gravity exerts but, if others such as height above the ground, etc. are mentioned, encourage them to examine them. The main relationship to encourage is the one between weight and mass. To collect the data to develop this relationship, students should hang varying masses on the scale or probe and get the force readings. Plotting a graph of force vs. mass should yield a straight line with a slope close to 9.8 N/kg. Avoid calling this the acceleration due to gravity at this point- just refer to it as the gravitational field strength.

Physics Curriculum Support Document

Demonstration: Impulse is Equal to Change in Momentum: Background Information

Demonstration: Impulse is Equal to Change in Momentum

Standard Course of Study Goals and Objectives

Goal 1: The learner will develop abilities necessary to do and understand scientific inquiry.

1.03 Formulate and revise scientific explanations and models using logic and evidence to:

- Explain observations.
- Make inferences and predictions.
- Explain the relationship between evidence and explanation.

GOAL 5: The learner will build an understanding of impulse and momentum.

5.02 Compare and contrast impulse and momentum.

5.03 Analyze the factors required to produce a change in momentum.

Materials

- One dynamics cart, with spring plunger (PASCO recommended)
- One force sensor attached to a ring stand
- One motion detector
- Lab interface (LabPro, ULI, Data Studio) with appropriate software
- Masses

Introduction to the Teacher

The purpose of this demonstration is to show that the change in momentum of a cart when it hits an obstacle (in this case, a force sensor) is equal to the impulse exerted by the force sensor. Additional benefits of this demonstration are that (1) the impulse is found by finding the area under the “curve” on a force vs. time graph; (2) the students have the opportunity to review a velocity vs. time graph; and (3) the students have the opportunity to review Newton’s 1st and 2nd laws.

Set up a track, cart, motion detector and force sensor as follows:

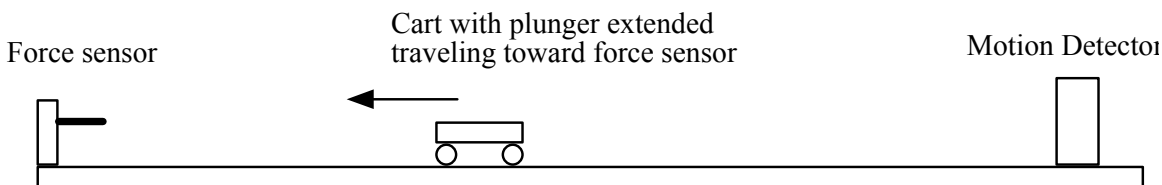

- Place a dynamics cart (with plunger extended) on a track and give it a push toward the force sensor, but stop it before it strikes the sensor. Ask students to

Physics Curriculum Support Document

Demonstration: Impulse is Equal to Change in Momentum: Background Information

describe the velocity of the cart after you have given it a push. They should respond that, neglecting friction, the cart will roll at constant velocity.

- Ask students to predict how the velocity will change when its plunger strikes the fixed force sensor. They will agree that the cart will reverse direction, but may not be sure what the velocity vs. time graph will look like.
- Start collecting data and roll the cart toward the sensor. If done properly, the cart should accelerate smoothly while the plunger is in contact with the sensor and return to its original position with a relatively constant, but somewhat lower speed.
- You should end up with a velocity vs. time graph that looks something like the following “ideal” graph which was created in Excel:

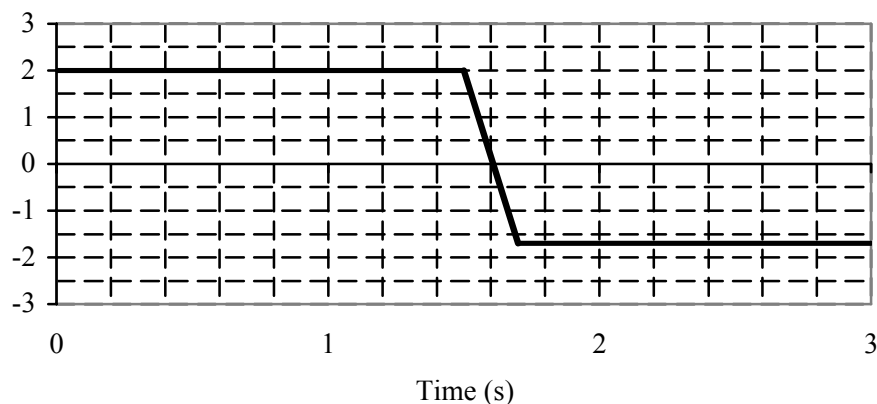

- Note that the velocity of the cart should be relatively constant when the force is zero, but changes during the interval over which the sensor applies a force to the plunger.
- Record the velocities of the cart before and after the collision and use these numbers, along with the mass of the cart, to determine the change in momentum of the cart. Students should note that the velocity after the cart is no longer in contact with the sensor is negative and that this negative value must be used in their calculations. For the example shown in the graph above, assume the mass of the cart is 500 grams. Then the change in momentum would be calculated as follows:

$$\Delta p = m (v_2 - v_1)$$

$$\Delta p = 0.5 \text{ kg } (-1.7 \text{ m/s} - 2.0 \text{ m/s})$$

$$\Delta p = -1.85 \text{ kgm/s}$$

June 2007

Physics Curriculum Support Document

Demonstration: Impulse is Equal to Change in Momentum: Background Information

- You should also end up with a force vs. time graph that looks something like the following “ideal” graph which was created in Excel:

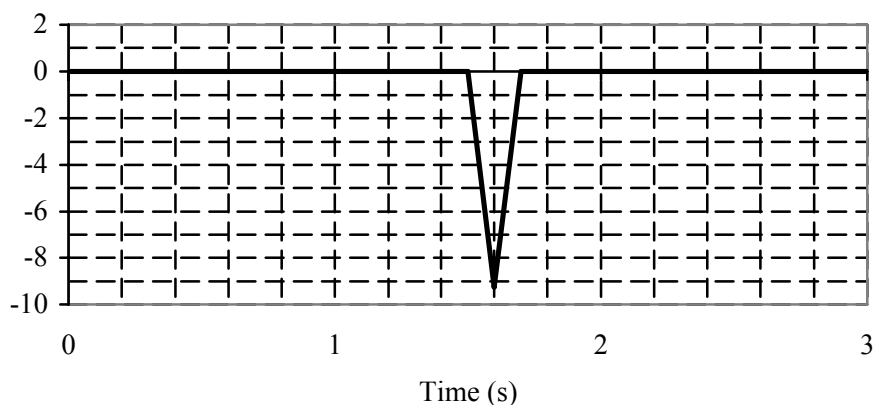

- Note that the negative values on the force vs. time indicate that the force was applied in the direction opposite the initial motion.
- Remind students that the area under the force vs. time graph is equal to the average force times the time, which is impulse.
- Most data collection packages have the option of determining the area under the curve on the force vs. time graph. When you find this area you can show that this area, which is the impulse exerted on the cart, is equal to the change in momentum of the cart.

References

The description of this lab demonstration was adapted from the Modeling Physics Curriculum, which can be found at the Arizona State University Modeling site: <http://modeling.asu.edu/Curriculum.html> by Susan Eldon (Northern High School, Durham, NC).

Physics Curriculum Support Document

Conservation of Momentum: Background Information

Conservation of Momentum

Standard Course of Study Goals and Objectives

Goal 1: The learner will develop abilities necessary to do and understand scientific inquiry.

1.01 Identify questions and problems that can be answered through scientific investigations.

1.03 Formulate and revise scientific explanations and models using logic and evidence to:

- Explain observations.
- Make inferences and predictions.
- Explain the relationship between evidence and explanation.

GOAL 5: The learner will build an understanding of impulse and momentum.

5.04 Analyze one-dimensional interactions between objects and recognize that the total momentum is conserved in both collision and recoil situations.

Materials

- Two dynamics carts and a track (PASCO recommended)
- Masses
- Graphical Analysis software (or some other graphing program)
- Motion detectors or photogates (optional)

Introduction to the Teacher

The purpose of this lab is for students to discover that momentum is conserved. In this lab the teacher's role is to guide students to design and conduct an investigation of the momentum of two carts that are initially held together and "explode" apart when the plunger is released. The teacher can lead the students through this process using a classroom discussion as explained below:

- Ask students to predict what will happen when two carts that are initially held together "explode" apart when the plunger is released.
- Help students identify the variables of mass and velocity (momentum).
- Lead the students to ask the question: "What effect does varying the masses of the carts have on the velocity of the carts?" or "What is the relationship between the momentum of one cart and the other cart as they explode apart?"
- Ask students for strategies to determine the velocities of both carts. Motion detectors and photogates work well, but if this equipment is unavailable students can also measure the distance the carts travel in the same amount of time, as shown below:

Physics Curriculum Support Document

Conservation of Momentum: Background Information

Example 1:

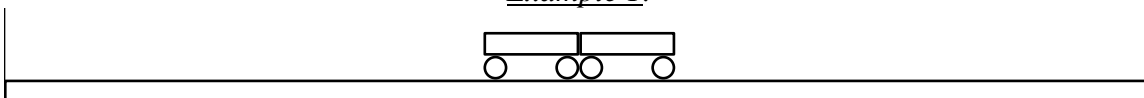

The carts start together, equal distances from the ends.

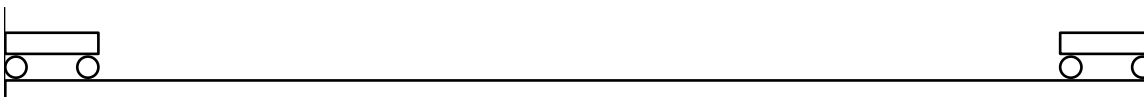

*When the carts have equal masses they travel the same distance in the same time.
The distances can easily be measured and are proportional to the speeds.*

Example 2:

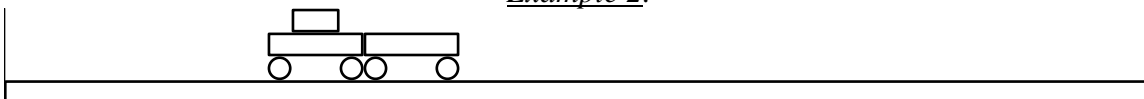

*When one cart has more mass than the other, their initial position is shifted (using trial and error) so that the time it takes for them to reach the ends is the same.
Again the distances can be easily measured and are proportional to the speeds.*

Students might end up with data like the following:

Cart #1		Cart #2	
Mass (g)	Distance (cm)	Mass (g)	Distance (cm)
250	90	250	90
300	82	250	98
400	69	250	111
500	60	250	120
300	108	450	72
250	120	500	60
300	131	800	49

Once the students have collected the data they can begin the analysis process

- Students can then graph the mass x distance (or momentum) of one cart vs. the mass x distance (or momentum) of the other cart to find a linear relationship with a slope of one showing that the momentum of one cart (p_1) is equal to the momentum of the other cart (p_2). [NOTE: If the above method is used the velocity is not actually known, only the distance, but since the time is the same for both carts mass x distance is proportional to momentum.]
- The graph might look something like this:

Physics Curriculum Support Document

Conservation of Momentum: Background Information

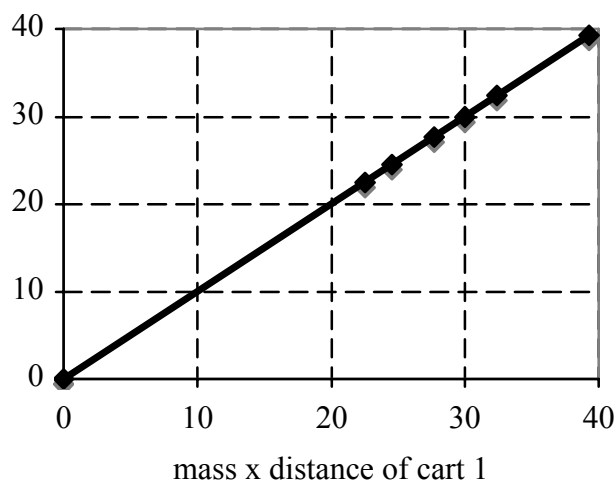

A classroom discussion of the results should guide students to discover that momentum is conserved. The following concepts should be brought up in the discussion:

- Since the slope of the line on the graph is 1 (or certainly within 10% of 1) the students should develop an equation as follows:

$$\text{mass of cart 1} \times \text{distance of cart 1} = \text{mass of cart 2} \times \text{distance of cart 2}$$

- The discussion should lead the students to recognize that since the time is the same in each example this equation can be written:

$$\text{mass of cart 1} \times \text{speed of cart 1} = \text{mass of cart 2} \times \text{speed of cart 2}$$

or

$$p_1 = p_2$$

- Since momentum is a vector quantity the discussion should lead students to the fact that

$$p_1 = -p_2$$

or

$$p_1 + p_2 = 0$$

- This equation shows that the momentum before the “explosion” is equal to the momentum after the “explosion” or that momentum is conserved in an “explosion”.

NOTE: This lab activity should be followed by a second lab or lab demonstration with various collisions (as suggested in 5.04) to show that momentum is conserved even when the total momentum initially is not zero.

References

Physics Curriculum Support Document

Conservation of Momentum: Background Information

This activity was adapted from a Modeling Physics Workshop at UNC-Greensboro led by Michael Turner during the summer of 2003 by Susan Eldon (Northern High School, Durham, NC).

Physics Curriculum Support Document

Spring Energy Activities: Background Information

Spring Energy Activities

Activity I: *Students will know the linear relationship between spring stretch from equilibrium and spring restoring force. Students will also know how to find energy stored in a spring using both a graph of spring force verses spring stretch as well as a mathematical statement of elastic potential energy.*

Standard Course of Study Goals and Objectives

Goal 1: The learner will develop abilities necessary to do and understand scientific inquiry.

1.02 Design and conduct scientific investigations to answer questions about the physical world.

- Create testable hypotheses.
- Identify variables.
- Use a control or comparison group when appropriate.
- Select and use appropriate measurement tools.
- Collect and record data.
- Organize data into charts and graphs.
- Analyze and interpret data.
- Communicate findings.

GOAL 6: The learner will develop an understanding of energy as the ability to cause change.

6.01 Investigate and analyze energy storage and transfer mechanisms:

- Gravitational potential energy.
- Elastic potential energy.
- Thermal energy.
- Kinetic energy.

Materials

- Springs (with various spring constants)
- Hanging masses
- Meter sticks

Introduction to the Teacher

Students should measure directly the stretch of a spring from equilibrium and the restoring force corresponding to that amount of stretch by hanging various amounts of mass from a spring. Newton's second law states that the force of the Earth pulling down on the hanging mass is balanced by an upward force of the spring on the hanging mass. Students should already be familiar with finding the force of the Earth on a hanging mass (its weight). A subsequent graph of spring force verses spring stretch should yield a linear relationship. The slope of this graph represents the spring constant for that particular spring. The equation of this graph is known as Hooke's Law:

$$F = -k \Delta x$$

Physics Curriculum Support Document

Spring Energy Activities: Background Information

The negative sign showing that the restoring force is in the opposite direction of the spring stretch.

Different groups of students can perform this experiment using different springs. A comparison of their results should reveal different sloped for each individual spring but a linear relationship for all springs.

Care should be taken in selecting both the springs to be used as well as the minimum force applied to the springs. Most springs need a minimum force to produce some stretch. This could produce graphs of force verses stretch that have a nonzero vertical intercept. The use of springs with relatively low spring constants should minimize problems in this area.

Extension

Teachers should show students that the area under the graph of spring force verses stretch represents the energy stored in the spring.

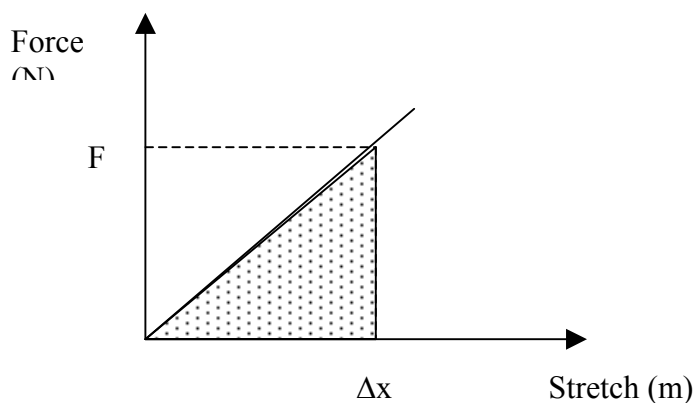

The area can be calculated by computing the area of the triangle of base Δx and height F . This yields:

$$\text{Area} = 1/2 \Delta x F$$

Remember that $F = k \Delta x$ so through substitution one obtains:

$$\text{Area} = 1/2 \Delta x (k \Delta x) = 1/2 k \Delta x^2$$

This final relationship represents the elastic potential energy stored in the spring.

Physics Curriculum Support Document

Spring Energy Activities: Background Information

A similar result can be obtained for gravitational potential energy.

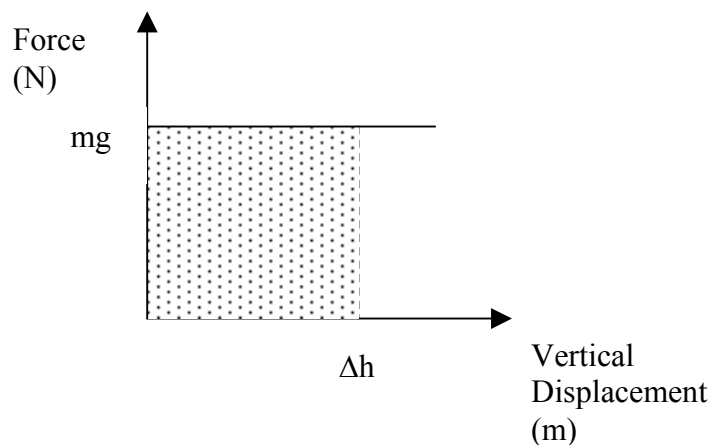

A graph of force (mg) needed to lift a mass (m) with a constant speed vertically through a distance (Δh) will yield a horizontal line. The area under this graph again represents the energy stored in the system. The calculated area:

$$\text{Area} = \text{length} * \text{width} = mg * h$$

This relationship represents the gravitational potential stored in the Earth-mass system.

Physics Curriculum Support Document

Spring Energy Activities: Background Information

Spring Energy Activities

Activity II: Students will derive the expression for kinetic energy and observe a system where mechanical energy is conserved.

Standard Course of Study Goals and Objectives

Goal 1: The learner will develop abilities necessary to do and understand scientific inquiry.

1.03 Formulate and revise scientific explanations and models using logic and evidence to:

- Explain observations.
- Make inferences and predictions.
- Explain the relationship between evidence and explanation.

GOAL 6: The learner will develop an understanding of energy as the ability to cause change.

6.01 Investigate and analyze energy storage and transfer mechanisms:

- Gravitational potential energy.
- Elastic potential energy.
- Thermal energy.
- Kinetic energy.

Materials

- Dynamics cart (very low friction)
- String
- Spring
- CBL or MBL motion detector or photogate

Introduction to the Teacher

Students should attach a spring horizontally to a rigid support (such as a ring stand) and tie a length of string to the other end of the spring. Attach the other end of the string to a dynamics cart. Using this system one can launch the dynamics cart using the stored energy of the stretched spring. Students can vary the amount of stored energy in the spring and measure the resulting velocity of the launched dynamics cart using either a motion detector or a photogate. A plot of cart velocity versus stored energy in the spring should yield a parabolic plot. A plot of v^2 versus stored energy should yield a linear plot. The slope of this plot should correspond to $2/m$ of the dynamics cart. See below.

Physics Curriculum Support Document

Spring Energy Activities: Background Information

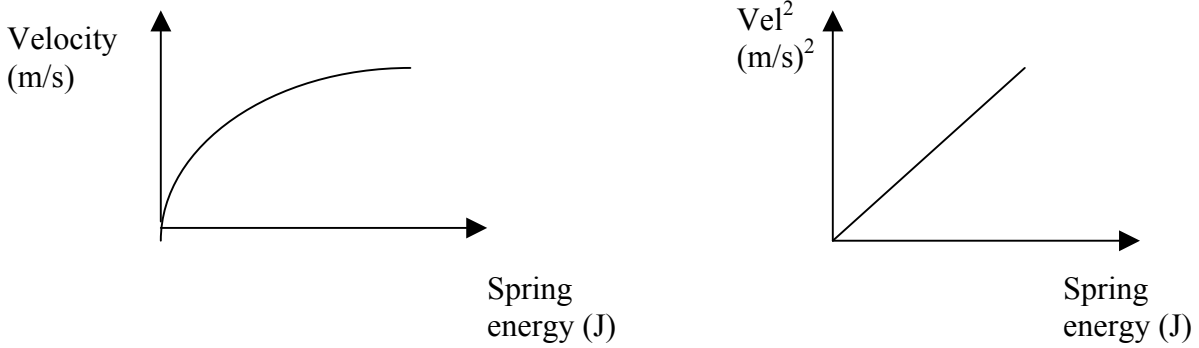

$$V^2 = 2/m * (\text{spring energy}) \text{ or}$$

$$1/2 * m * v^2 = \text{spring energy}$$

The energy stored in the spring is transferred to energy of motion of the dynamics cart (or kinetic energy).

Extension

Similar labs can compare the gravitational potential energy stored in objects to their kinetic energy after falling through that height. These should again show that total energy of the system is conserved.

Physics Curriculum Support Document

Waves and Springs: Background Information

Waves and Springs Activities

Activity I: *Students will learn that wave speed is only dependent on the medium.*

Standard Course of Study Goals and Objectives

Goal 1: The learner will develop abilities necessary to do and understand scientific inquiry.

1.03 Formulate and revise scientific explanations and models using logic and evidence to:

- Explain observations.
- Make inferences and predictions.
- Explain the relationship between evidence and explanation.

GOAL 7: The learner will develop an understanding of wave motion and the wave nature of sound and light.

7.02 Describe the behavior of waves in various media.

Materials

- Snaky spring (the long thin kind, not a slinky)
- Video Camera & VCR with frame by frame advance (most 4-head VCR's can do frame by frame advance using the pause button)

Introduction to the Teacher

Have 2 students stretch a snaky spring across the floor (about 5m) holding each end tightly. Create wave pulses in the spring by placing the toe of your shoe against the spring about 1 m from one fixed end. Pull and release with your hand between your foot and the fixed end to create a wave pulse of desired amplitude. Videotape the motion of the pulse using the video camera. Pulse speed can be determined using the distance between fixed ends and the number of frames to travel from one end to the other. Each frame represents one thirtieth of a second. Have students predict what variables they think may affect pulse speed. Students usually predict tightness of the spring, heaviness of the spring, size of the pulses (amplitude), distance between the ends, etc. Each of these variables can be tested using the spring and video system. Ultimately students will learn that only the variables related to the medium itself (such as tension or density) affect pulse speed. Tying the spring to a rope and allowing the pulses to pass from the spring to the rope can test density. A noticeable change of pulse speed can be detected as it passes from the spring to the rope.

This concrete example can be carried over to other types of waves (such as light waves) and their speed dependence on medium.

Physics Curriculum Support Document

Waves and Springs: Background Information

Waves and Springs Activities

Activity II: *Students will learn how waves combine through constructive and destructive interference.*

Standard Course of Study Goals and Objectives

Goal 1: The learner will develop abilities necessary to do and understand scientific inquiry.

1.03 Formulate and revise scientific explanations and models using logic and evidence to:

- Explain observations.
- Make inferences and predictions.
- Explain the relationship between evidence and explanation.

GOAL 7: The learner will develop an understanding of wave motion and the wave nature of sound and light.

7.04 Analyze the relationship between the phenomena of interference and the principle of superposition.

Materials

- Snaky spring (the long thin kind, not a slinky)
- Video Camera & VCR with frame by frame advance (most 4-head VCR's can do frame by frame advance using the pause button)

Introduction to the Teacher

Have 2 students stretch a snaky spring across the floor (about 5m) holding each end tightly. Create wave pulses in the spring by placing the toe of your shoe against the spring about 1 m from one fixed end. Pull and release with your hand between your foot and the fixed end to create a wave pulse of desired amplitude. Have 2 more students create these pulses simultaneously from each end traveling toward each other. Placing cups (Styrofoam or plastic) on either side of the spring can emphasize the effects of constructive and destructive interference. For destructive interference place the cups close enough to the spring so the traveling pulses knock down the cups. When the pulses are released all cups will be knocked down except the ones in the middle where the destructive interference occurs. For constructive interference place the cups farther away from the spring than the amplitude of a single pulse. When the pulses combine the larger amplitude will be enough to knock down only those cups at that point. Videotaping the motion of the wave pulses and replaying them frame-by-frame can emphasize all effects in this exercise.

This concrete example of wave interference can be extended to other kinds of waves (water, sound, light) and is particularly useful when developing diffraction and interference of light.

Physics Curriculum Support Document

Reflection and Refraction: Background Information

Reflection and Refraction Activities

Activity I: Students will know the relationship between the incident angle of a light ray and its angle of reflection. This relationship, known as the law of reflection, states that these angles are always equal. Students will also know how to locate a virtual image in a plane mirror using the law of reflection and light ray diagrams.

Standard Course of Study Goals and Objectives

Goal 1: The learner will develop abilities necessary to do and understand scientific inquiry.

1.03 Formulate and revise scientific explanations and models using logic and evidence to:

- Explain observations.
- Make inferences and predictions.
- Explain the relationship between evidence and explanation

GOAL 7: The learner will develop an understanding of wave motion and the wave nature of sound and light.

7.03 Analyze the behavior of waves at boundaries between media:

- Reflection, including the Law of Reflection.
- Refraction, including Snell's Law.

Materials

- Small plane mirrors
- Sight tube (see below)
- Protractor
- Construction of sight tube
- Index card
- Straw or tube made from rolled up paper
- Hole puncher

Introduction to the Teacher

Fold the index card in half and punch a hole midway along the side opposite the fold about 1 centimeter from that edge. This hole should go through both pieces of the index card.

Feed straw or rolled tube of paper through both holes. Pull the edges of the index card closest to the punched hole apart slightly, so it can stand freely. The straw or tube should be about 1 centimeter above the surface of the table on which the folded card rests.

Physics Curriculum Support Document

Reflection and Refraction: Background Information

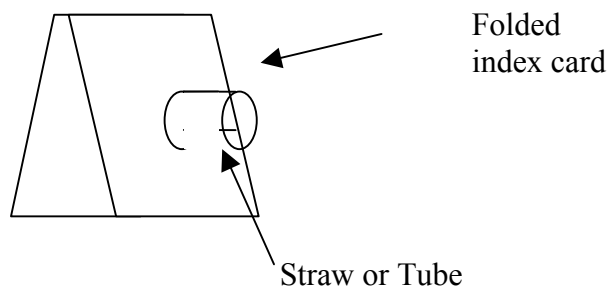

Mount the plane mirror on a wooden block and place them on a piece of paper on a tabletop so the reflecting surface of the mirror is in contact with and perpendicular to the paper. Place the sight tube on the paper so the tube establishes a line of sight to the mirror that is not perpendicular to the mirror. Next place a freestanding object (pen works well) in front of the mirror whose image lines up with the line of sight established by the sight tube. Students looking through the sight tube should see the center of the freestanding object. Draw marks on the paper at either end of the sight tube and also at the location of the freestanding object. Also draw a line on the paper directly along the surface of the mirror. Remove mirror, sight tube, and object from paper surface. Draw a line connecting the two marks on either end of the sight tube that extends to and intersects the mirror surface. Draw another line from this point of intersection to the center of the object's location. These lines represent the path a light ray follows from the center of the object to the mirror reflecting through the sight tube into the eye of the observer.

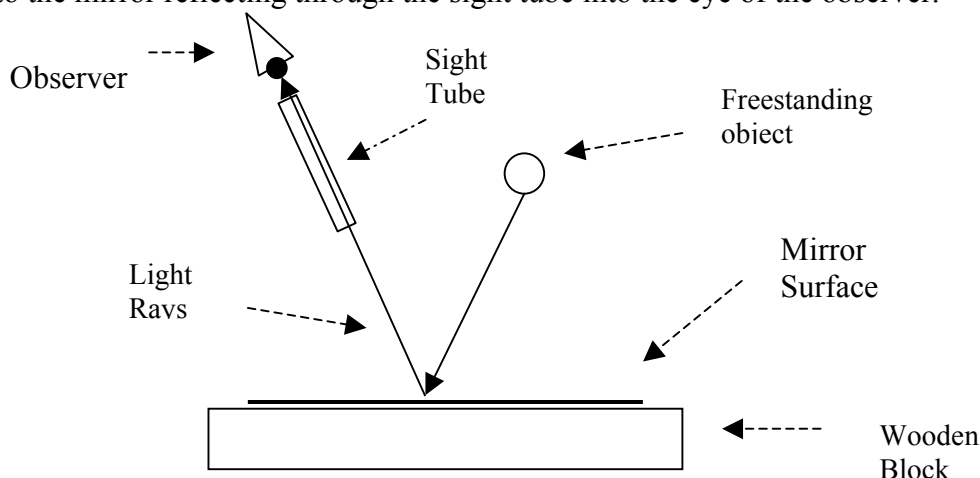

Draw a line normal to the line representing the mirror surface using a protractor. Angles of incidence and reflection can be directly measured from this diagram. Students can vary the location of the sight tube and object to collect data on various angles of incidence and reflection. A graph of reflected angle versus incident angle will yield a direct proportionality with a slope of one. (Some lab groups may get slopes slightly different than one but an average across several groups usually yields results very close to one.) This graph shows that the angle of incidence is equal to the angle of reflection, which is the law of reflection.

Physics Curriculum Support Document

Reflection and Refraction: Background Information

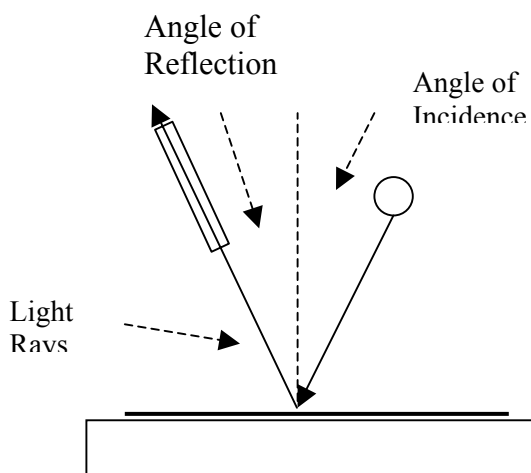

Extension

Images can be located using diagrams by taking two different sightings of the same object from different locations as shown below. The extension of the reflected rays backwards through the mirror as virtual rays established the location of the virtual image. Careful diagrams reveal that the virtual image is the same distance from the mirror as the object.

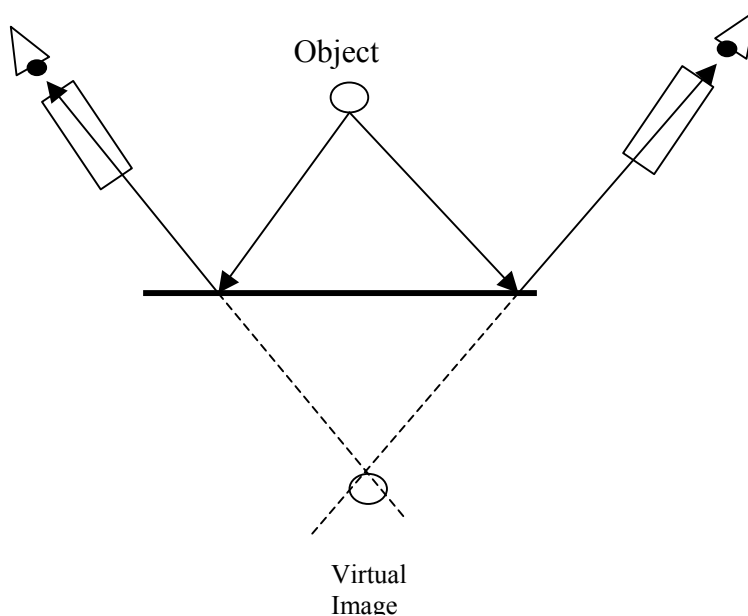

Physics Curriculum Support Document

Reflection and Refraction: Background Information

Reflection and Refraction Activities

Activity II: Students will derive the relationship for Snell's Law using light refraction through water.

Standard Course of Study Goals and Objectives

Goal 1: The learner will develop abilities necessary to do and understand scientific inquiry.

1.03 Formulate and revise scientific explanations and models using logic and evidence to:

- Explain observations.
- Make inferences and predictions.
- Explain the relationship between evidence and explanation

GOAL 7: The learner will develop an understanding of wave motion and the wave nature of sound and light.

7.03 Analyze the behavior of waves at boundaries between media:

- Reflection, including the Law of Reflection.
- Refraction, including Snell's Law.

Materials

- Semicircular plastic refraction dish (available in science supply catalogues)
- Protractor

Introduction to the Teacher

Students should place refraction dish on a sheet of paper and fill three quarters with water. Trace around the refraction dish and mark the center point along the flat side of the dish on the paper. Place an object (such as a pen) on the paper on the flat side of the dish to one side of a normal line drawn from the midpoint of the flat side. Place a sight tube (see reflection from a plane mirror activity for instructions on making a sight tube) on the curved side of the refraction dish and line up the sight tube with the image of the pen as seen through the water.

Physics Curriculum Support Document

Reflection and Refraction: Background Information

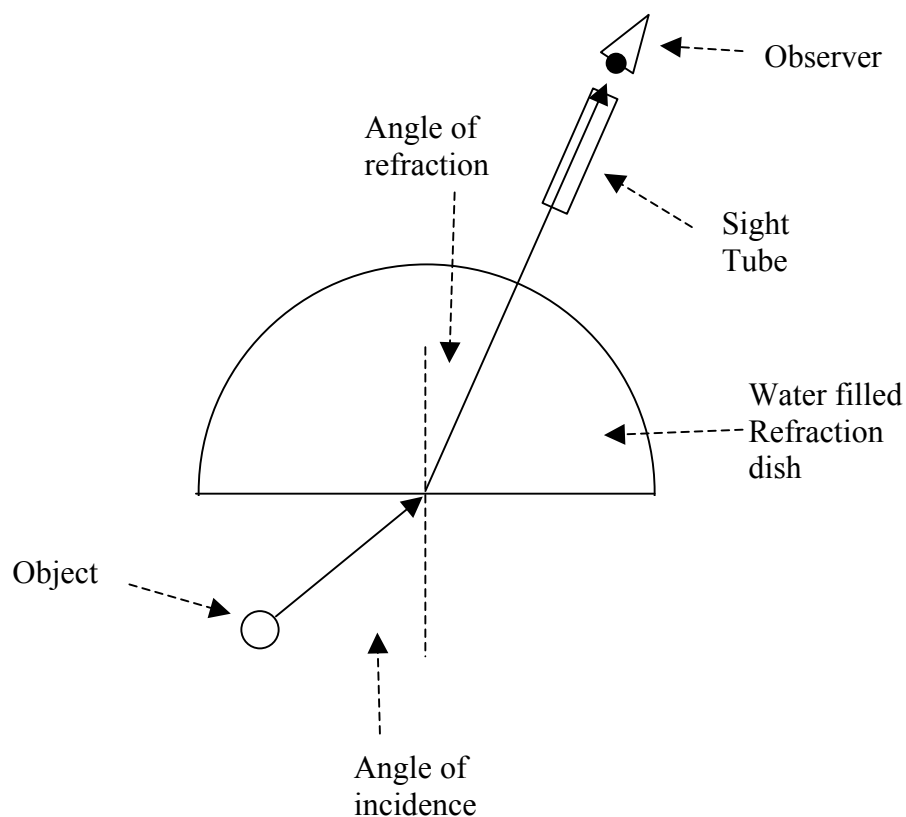

Marks drawn on the paper at either end of the sight tube can be connected and extended to the boundary between the air and the flat side of the tray where the light entered the water. Another line should be drawn from this point of intersection to the location of the object. After drawing a normal line at surface where the light enters the water angles of incidence and refraction can be measured with a protractor. Students can vary the angles of incidence and refraction by changing the location of the object and sight tube. After collecting the data students should plot a graph of angle of incidence versus angle of refraction. This relationship can be made linear by plotting the sine of the angle of incidence versus the sine of the angle of refraction. This linear graph should pass through the origin and have a slope around 1.33. This slope represents the index of refraction for water.

Extension

This experiment can be repeated using a different refracting medium such as cooking oil or glass if available. Varying degrees of refraction will be observed with different slope values of the plot of sine of incident angle versus sine of refracted angle. These graphs can be generalized to Snell's Law:

$$n_i \sin \theta_i = n_r \sin \theta_r$$

Physics Curriculum Support Document

Reflection and Refraction: Background Information

Students can also repeat the experiment by placing the object on the curved side of the refracting dish and the sight tube on the flat side. This produces the circumstances needed for total internal reflection. Students can observe and measure the critical angle and compare these results to those given by calculation.

Physics Curriculum Support Document

Doppler Effect: Background Information

Doppler Effect

Standard Course of Study Goals and Objectives

Goal 1: The learner will develop abilities necessary to do and understand scientific inquiry.

1.03 Formulate and revise scientific explanations and models using logic and evidence to:

- Explain observations.
- Make inferences and predictions.
- Explain the relationship between evidence and explanation.

GOAL 7: The learner will develop an understanding of wave motion and the wave nature of sound and light.

7.05 Analyze the frequency and wavelength of sound produced by a moving source (the Doppler Effect).

Materials

- Pencil
- Paper
- Compass for drawing circles of various sizes

Introduction to the Teacher

Students will know that perceived sounds are different in frequency and wavelength than the source sound when there is relative motion between the source of the sound and the detector of the sound.

Have students draw a small diagram of a stationary car on a sheet of graph paper. Tell them to imagine the car blowing its horn and what the sound waves might look like as they are emitted. One could represent these waves in a diagram as a series of concentric circles starting at the car and moving out in all directions.

Since these waves move with constant velocity and are produced by one constant frequency then the circles that represent the wave fronts should increase in radius by a constant amount. The diagram below shows the first three sound wave fronts emitted by the car horn. Notice the first wave front is the one with the largest radius.

Physics Curriculum Support Document

Doppler Effect: Background Information

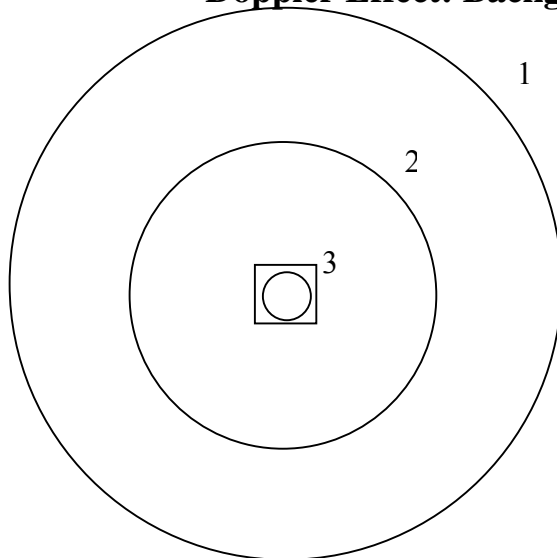

Next, have the students draw the diagram for a moving car blowing its horn. First draw a box for the car at its initial position and a large circle that represents the wavefront generated at that initial position. Then draw another box representing the car at a different position at a later time. Draw a smaller circle, centered on that second box, representing the wavefront generated from that location. Repeat this again for a third location for the car at a later time. You will wind up with a diagram like the one below.

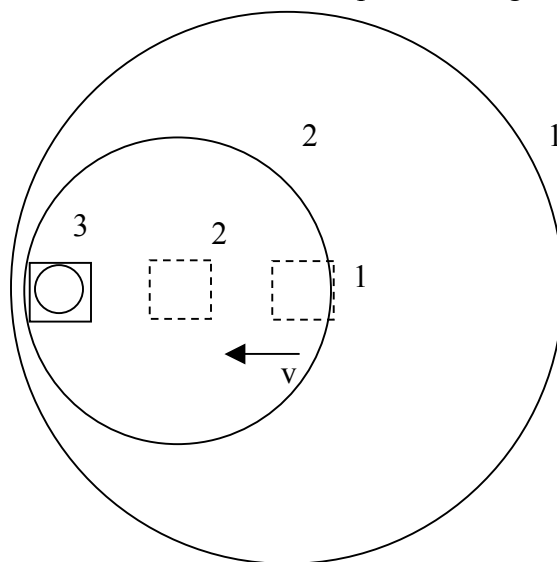

From these diagrams students can see the perceived change in wavelength and frequency if the source of the sound waves is either moving toward or away from the observer.

Extension

Students can be challenged to create diagrams to show the effect of the perceived sound if the source is stationary but the observer is either moving toward or away from the source.

June 2007

Physics Curriculum Support Document

Sticky Tape: Background Information

Sticky Tape Lab

Standard Course of Study Goals and Objectives

Goal 1: The learner will develop abilities necessary to do and understand scientific inquiry.

1.01 Identify questions and problems that can be answered through scientific investigations.

1.05 Analyze reports of scientific investigations of physical phenomena from an informed scientifically literate viewpoint including considerations of:

- Adequacy of experimental controls.
- Replication of findings.
- Alternative interpretations of the data.

GOAL 8: The learner will build an understanding of static electricity and direct current electrical circuits.

8.01 Analyze the nature of electrical charges.

- Investigate the electrical charging of objects due to transfer of charge.
- Investigate the conservation of electric charge.
- Analyze the relationship among force, charge and distance summarized in Coulomb's law.

Materials

- Transparent tape
- Soda can
- Styrofoam cup.

Introduction to the Teacher

Students should know after this lesson that the force between static charges varies directly with the magnitude of the charges and inversely with the square of the distance between the charges.

Use transparent tape to set up a static charge. Place a piece of tape sticky side down on the table. Make a non-sticky handle on one end of another piece of tape by folding over one centimeter of the tape. Then put the second piece of the tape sticky side down on the first base tape. Pull the tape off quickly. This will put a static charge on the tape.

Oppositely charged tapes can be made if two tapes are placed on the base tape and pulled off as one. Then the two tapes can be pulled apart. These charged tapes work in conditions of high humidity. Place the charged tape onto the edge of the table and bring various objects near the tape. These labs with transparent tape are described in detail in [Electric and Magnetic Interactions](#) by Ruth Chabay and Bruce Sherwood, John Wiley and Sons, New York, 1995. Similar labs are described in the [Teaching About Electrostatics AAPT/PTRA-PLUS Workshop](#) by Robert Morse, American Association of Physics Teachers, College park, Md, 1992.

Physics Curriculum Support Document

Sticky Tape: Background Information

Tape an empty soda can on top of a Styrofoam cup. Bend the pull-tab so that it is 90° to the rest of the can. Hang a piece of Christmas tree tinsel from the tab. This forms an inexpensive electroscope. Bring various charged objects near the soda can.

References

- These labs with transparent tape are described in detail in Electric and Magnetic Interactions by Ruth Chabay and Bruce Sherwood, John Wiley and Sons, New York, 1995. Similar labs are described in the Teaching About Electrostatics AAPT/PTRA-PLUS Workshop by Robert Morse, American Association of Physics Teachers, College park, Md, 1992.
- **Sample physlets from the Internet:**
http://webphysics.davidson.edu/physletprob/ch9_problems/ch9_1_electrostatics/default.html
- “Interactive Physics II” and “Interactive Physics 2000” software programs allow static charge interactions to be simulated. This software is available from MSC Software. <http://www.macsch.com/>

Physics Curriculum Support Document

Circuit: Background Information

Circuit Activity

Standard Course of Study Goals and Objectives

GOAL 1: The learner will develop abilities necessary to do and understand scientific inquiry.

1.02 Design and conduct scientific investigations to answer questions about the physical world.

- Create testable hypotheses.
- Identify variables.
- Use a control or comparison group when appropriate.
- Select and use appropriate measurement tools.
- Collect and record data.
- Organize data into charts and graphs.
- Analyze and interpret data.
- Communicate findings.

GOAL 8: The learner will build an understanding of static electricity and direct current electrical circuits.

8.02 Analyze and measure the relationship among potential difference, current, and resistance in a direct current circuit.

Introduction to the Teacher

An excellent introductory activity is to provide each student with one dry cell, one wire and a flashlight bulb or other small screw-in light bulb. Ask the students to make the light bulb light in as many ways as they can. Have them record the things that work and don't work. Then the students can work in small groups to determine the patterns that can be determined from the data. Break the glass bulb of several light bulbs and allow the students to look at them. Help the students notice that one of the ends of the filament wire goes straight into the base and that the other end of the filament wire is soldered to the side of the light bulb base.

Safety Considerations

Be careful with broken glass. Dispose of the glass carefully.

Physics Curriculum Support Document

Ohm's Law: Background Information

Ohm's Law Activity

Standard Course of Study Goals and Objectives

GOAL 1: The learner will develop abilities necessary to do and understand scientific inquiry.

1.03 Formulate and revise scientific explanations and models using logic and evidence to:

- Explain observations.
- Make inferences and predictions.
- Explain the relationship between evidence and explanation.

GOAL 8: The learner will build an understanding of static electricity and direct current electrical circuits.

8.02 Analyze and measure the relationship among potential difference, current, and resistance in a direct current circuit.

8.03 Analyze and measure the relationship among current, voltage, and resistance in circuits.

- Series.
- Parallel.
- Series-parallel combinations.

Introduction to the Teacher

The following lab allows the student to determine the Ohm's Law relationship experimentally. Be sure to use 10-watt power resistors or wire wound resistors. These power resistors are not the ones that are marked with the traditional color code. These resistors are ceramic. (Radio Shack resistors 271-131, 271-132, 271-133, and 271-135 work well for this lab. They come two in a package and cost about \$1.00.) Make sure to mark out the resistance rating before you give the resistors to the student groups.

Each student group should be given at least six 1.5-volt dry cells, one resistor, an ammeter and a voltmeter. (The Vernier universal lab interface, the Pasco science workshop interfaces, the Texas Instruments Calculator based lab interfaces, and other lab interfaces can be used as a voltmeter.) Have the students set up a simple series circuit with one resistor and one dry cell. Then have them measure the current and the voltage. This process is repeated as the students add more dry cells to the set up. The lab data is then plotted with the potential difference (voltage) on the y-axis and the current on the x-axis. As the students analyze the data and apply a mathematical relationship to it, they should determine that there is a direct relationship between voltage and current. Have them find the slope of the best-fit line for the graph. Then they can use the accepted value for the resistance (it is marked on the package) and the experimental value to calculate the percent error in the lab.

Each student group should be given a voltage source, three or four resistors, an ammeter and a voltmeter. (The Vernier universal lab interface, the Pasco science workshop interfaces, the Texas Instruments Calculator based lab interfaces, and other lab interfaces can be used as a voltmeter.) Have the students set up a simple series circuit with one

Physics Curriculum Support Document

Ohm's Law: Background Information

resistor and one dry cell. Then have them measure the current and the voltage. This process is repeated as the students add more resistors in series to the set up. The potential difference (voltage), resistance, and current should be recorded in a table. Have the students plot the data and determine the mathematical relationship between the resistance and the current. As the students analyze the data and apply a mathematical relationship to it, they should determine that there is an indirect relationship between resistance and current.

Each student group should be given a voltage source, three or four resistors, an ammeter and a voltmeter. (The Vernier universal lab interface, the Pasco science workshop interfaces, the Texas Instruments Calculator based lab interfaces, and other lab interfaces can be used as a voltmeter.) Have the students set up a simple circuit with one resistor and one dry cell. Then have them measure the current and the voltage. This process is repeated as the students add more resistors in parallel to the set up. The potential difference (voltage), resistance, and current should be recorded in a table. Have the students plot the data and determine the mathematical relationship between the resistance and the current. As the students analyze the data and apply a mathematical relationship to it, they should determine that there is an inverse relationship between resistance and current.

Safety Considerations

Be careful when working with electricity.

Physics Curriculum Support Document

Verifying Ohm's Law: Background Information *Verifying Ohm's Law*

Standard Course of Study Goals and Objectives

GOAL 1: The learner will develop abilities necessary to do and understand scientific inquiry.

1.02 Design and conduct scientific investigations to answer questions about the physical world.

- Create testable hypotheses.
- Identify variables.
- Use a control or comparison group when appropriate.
- Select and use appropriate measurement tools.
- Collect and record data.
- Organize data into charts and graphs.
- Analyze and interpret data.
- Communicate findings.

GOAL 8: The learner will build an understanding of static electricity and direct current electrical circuits.

8.02 Analyze and measure the relationship among potential difference, current, and resistance in a direct current circuit.

8.03 Analyze and measure the relationship among current, voltage, and resistance in circuits.

- Series.
- Parallel.
- Series-parallel combinations.

Materials for Teacher

- One variable voltage DC power supply, one ammeter and one voltmeter (or two multimeters) per group of 2 – 4 students.
- Various resistors.
- Various connecting wires.
- Graphing software.

Introduction to the Teacher

Prior to doing this lab students must already have a solid understanding of current, voltage and resistance

Pre-Lab Discussion:

1. Review the definitions of current and voltage.
2. Draw a simple circuit on the board and introduce the concept of a variable voltage power supply (see diagram in attached teacher resource for clarity).
3. Ask the students to predict what will happen to the current in the circuit if the voltage of the power supply is increased.
4. Encourage a class discussion of these predictions. Some students will predict that the current will remain constant while others will predict that the current will increase. Allow the students to apply their knowledge of current and voltage to

Physics Curriculum Support Document

Verifying Ohm's Law: Background Information

discuss the rationale for their predictions. It is okay if the class does not reach consensus on their prediction.

5. Students will now want to know the answer to the question, "What is the relationship between current and voltage in a simple circuit?"
6. Have students record their prediction, including their rationale.

Discussion of Procedures for Collecting Data:

1. Students will quickly recognize that there are two variables: voltage is the independent variable and current is the dependent variable. They may have more trouble recognizing that the resistor will be constant for a given set up.
2. Ask students how they will measure current and voltage. Lead them to recognize (recall) that the ammeter can be placed on either side of the resistor and the voltmeter can be placed across either the power supply or the resistor (see diagram in attached teacher resource for clarity).
3. You may want to recommend that each group use a different resistor, preferably with a resistance of 100 ohms or more. If the resistance is too low the current may be high enough to burn the resistor.
4. Ask the student how much data they will need to collect. As a general rule, 10 data points that vary significantly will show the trends. It is advisable to keep the voltage below 15 volts and the current below 250 milliamps, depending on your equipment.
5. **SAFETY CONCERN:** The resistor can get very hot. Remind students to turn off their power supply between measurements and not to touch the resistor until it has had time to cool off.

Data Collection and Analysis:

1. Allow students to work in groups of 2 – 4 students per set up.
2. Circulate to make sure each setup is correct before students begin collecting data.
3. Assist students with recording relevant data, including the resistance of the resistor used.
4. Circulate to assist groups as needed.
5. When students are done collecting data they should create their graph. Data analysis is easier if they plot the independent variable, voltage, on the vertical axis and the dependent variable, current, on the horizontal axis. Data analysis is also facilitated if units of amps are used instead of milliamps.
6. Students should write the equation for their curve using correct variables.

Post-Lab Discussion (this can be done using white boards and having students lead the discussion or it can be a teacher-led discussion):

1. The data collected should show a direct proportion between current and voltage (see diagram in attached teacher resources for clarity).
2. The form of the equation for the line should be voltage = (slope) current.
3. By comparing the class data students should become aware of the fact that the slopes of the lines are different and they should recognize that the slopes are very close (usually within 10%) to the resistances of the resistors used.

Physics Curriculum Support Document

Verifying Ohm's Law: Background Information

4. Further discussion should allow the students to generalize their equation to $V = RI$ or $V = IR$, and to recognize that the units for the slope of V/A must be equal to the unit for resistance, ohms.
5. Conclude the discussion by helping students recognize that there is an inverse relationship between current and resistance.

Lab Report – should include the following:

1. A statement of the purpose of the lab.
2. Clear diagram of set up.
3. Data table.
4. Graph with best-fit curve.
5. Equation of the line using correct variables and units.
6. A thorough explanation of the equation of the line, including the significance of the slope.
7. A discussion of the results, relating them back to the purpose of the lab and showing some understanding of the reason for the results.
8. A discussion of sources of error in the lab and the effect this error had on the data.

See attached student handout for lab.

Follow-Up:

1. Students need practice with applying the equation $V = IR$ both conceptually and mathematically.
2. Students also need to become familiar with the units and the relationship between these units.

Safety Considerations

1. The voltmeter should always be “ACROSS” the input leads, or “IN PARALLEL” with the device since it is measuring a “potential difference”.
2. The ammeter should always be “IN-LINE” with, or “IN SERIES” with the resistor since it is measuring the current in the wire. Failure to do this will damage the meters.
3. Be extremely careful with all of the equipment. The resistors can get very hot. Ask if you are unsure of anything in your set up.

References

This activity was created by Susan Eldon (Northern High School, Durham, NC).

Physics Curriculum Support Document

Verifying Ohm's Law: Background Information

Ohm's Law Lab: Teacher Answers

1. If you are unfamiliar with schematic diagrams, check your textbook.
2. An initial diagram for students should look like this:

battery

connecting wire connecting wire

resistor

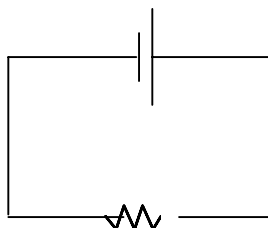

3. Introduce the symbol for a variable voltage power supply.
4. Once students recognize that an ammeter and a voltmeter must be added, the diagram can be modified to any of the following:

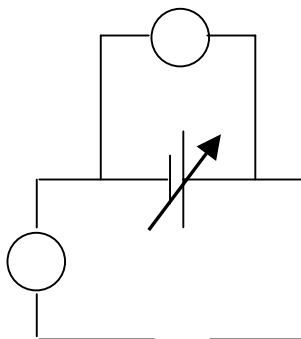
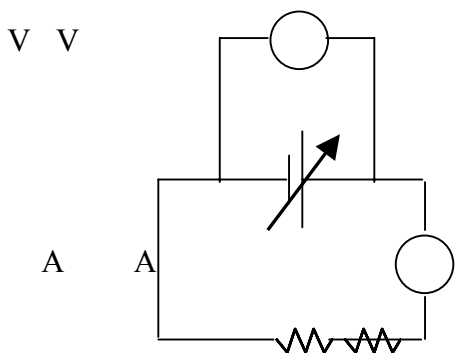
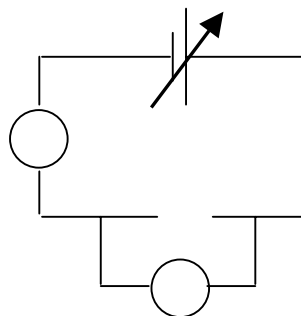
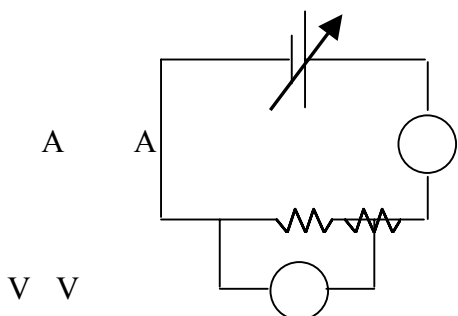

5. Data and Graph to help with analysis:
Table 1: Current vs. Voltage for a 150 ohm Resistor

Current (amps)	Voltage (volts)
0.0120	1.52
0.0166	2.44
0.0264	3.98

Physics Curriculum Support Document

Verifying Ohm's Law: Background Information

0.0341	5.10
0.0480	6.76
0.0552	8.57
0.0633	9.38
0.0774	11.2
0.0899	13.4
0.0965	14.8

Graph 1: Voltage vs. Current

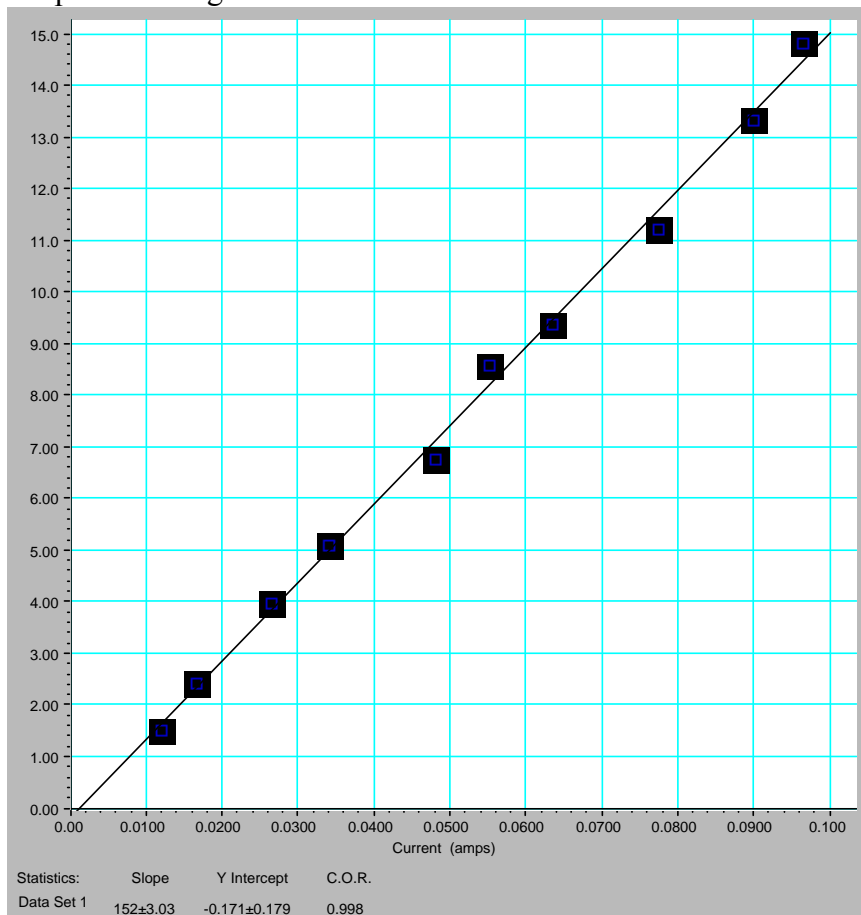

6. Equation of Line:

$$\text{Voltage} = (152 \text{ V/A}) \text{ Current} - 0.171 \text{ V}$$

The y-intercept, -0.171 V , is insignificant and can be eliminated.

The slope, 152 V/A , is very close to the resistance of the resistor, 150 ohms . From this students can conclude that $\text{V/A} = \text{ohms}$ and calculate a percent error:

$$\% \text{ error} = (152 \text{ ohms} - 150 \text{ ohms}) / 150 \text{ ohms} \times 100 = 1.3 \%$$

Physics Curriculum Support Document

Verifying Ohm's Law: Laboratory

Verifying Ohm's Law

Purpose

The purpose of this lab is to determine the relationship between current and voltage in a simple circuit, to collect, analyze and interpret data, and to derive the equation $V = IR$

Materials

- Paper
- Pencil
- Calculator

Introduction to Students

Use the following table to help you decipher the color-coding for the resistors you will use over the next several labs.

Resistor Color Codes

COLOR BAND 1 BAND 2 BAND 3 BAND 4

Black	0	0	10^0	---
Brown	1	1	10^1	---
Red	2	2	10^2	---
Orange	3	3	10^3	---
Yellow	4	4	10^4	---
Green	5	5	10^5	---
Blue	6	6	10^6	---
Violet	7	7	10^7	---
Gray	8	8	10^8	---
White	9	9	10^9	---
Gold	---	---	10^{-1}	5%
Silver	---	---	10^{-2}	10%

To read the code, find the end which has a silver or gold band and put that on your right. Then record the colors from left to right, and change the colors into digits using the above code.

For example, suppose the color code were red, orange, black, gold.

Converting, this is 2, 3, 10^0 , 5%. You should interpret this to be $23 \times 10^0 \Omega \pm 5\%$ or $23 \Omega \pm 1.2 \Omega$.

Safety Considerations

1. The voltmeter should always be “ACROSS” the input leads, or “IN PARALLEL” with the device since it is measuring a “potential difference”.
2. The ammeter should always be “IN-LINE” with, or “IN SERIES” with the resistor since it is measuring the current in the wire. Failure to do this will damage the meters.

Physics Curriculum Support Document

Verifying Ohm's Law: Laboratory

3. Be extremely careful with all of the equipment. The resistors can get very hot. Ask if you are unsure of anything in your set up.

COMMON SYMBOLS FOR SCHEMATIC DIAGRAMS:

A  Resistor

— —

V  Variable Resistor

—  —

 Power Supply / Battery

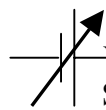
 Variable Voltage Power Supply

Questions to Guide Analysis

1. What is the purpose of the lab?
2. What was your prediction and justification for your prediction?
3. Draw and label a schematic diagram of your setup, using the symbols shown in the lab.
4. Indicate the color code for your resistor and record its numerical value (see page 1 for an example).
5. Include a data table with your data. Follow rules for data tables!
6. Include a graph of your data with a best-fit curve. Follow rules for graphs!
7. Analysis:
 - a. Include a brief written statement of the relationship shown in your graph.
 - b. Record the equation for your best-fit curve using correct symbols and units. Watch s.f.
 - c. If you eliminate the y-intercept give a justification.
8. Questions: *Answer questions using complete sentences. A person reading your answer should know what the question was from the wording of your answer!*
 - a. Clearly state the relationship you found in this lab.

Physics Curriculum Support Document

Verifying Ohm's Law: Laboratory

- b. Discuss the significance of the constant(s) in your equation. Explain how you know what the constants mean.
- c. Calculate the relevant percent error. (Don't know what it is? Ask someone!)
- d. Is there much error in your data? What are the possible sources of error in this lab?
- e. What is the general form of the equation the class discovered in this lab?

Extension

At a conceptual level, visualizing the charges moving through the wires, describe why the relationship you found in this lab is valid.

Physics Curriculum Support Document

Current and Voltage for Resistors in Series, Parallel, and Mixed Circuits: Background Information

Current and Voltage for Resistors in Series, Parallel, and Mixed Circuits

Standard Course of Study Goals and Objectives

GOAL 1: The learner will develop abilities necessary to do and understand scientific inquiry.

1.02 Design and conduct scientific investigations to answer questions about the physical world.

- Create testable hypotheses.
- Identify variables.
- Use a control or comparison group when appropriate.
- Select and use appropriate measurement tools.
- Collect and record data.
- Organize data into charts and graphs.
- Analyze and interpret data.
- Communicate findings.

GOAL 8: The learner will build an understanding of static electricity and direct current electrical circuits.

8.02 Analyze and measure the relationship among potential difference, current, and resistance in a direct current circuit.

8.03 Analyze and measure the relationship among current, voltage, and resistance in circuits.

- Series.
- Parallel.
- Series-parallel combinations.

Materials for Teacher

- A power supply or battery pack (2 or 3 D-cells) and a multimeter per group of 2 – 4 students.
- Various resistors.
- Various connecting wires

Introduction to the Teacher

These lab activities can easily be done immediately after the Ohm's Law lab. Students must be familiar with drawing schematic diagrams, with reading resistor codes, with using the equation $V = IR$, and with using a multimeter in a circuit as both an ammeter and a voltmeter.

Pre-Lab Discussion:

1. Build three circuits to introduce these lab activities: the first with a single bulb and battery pack, the second with two identical bulbs in series with a battery pack, the third with two identical bulbs in parallel with a battery pack. Note: These can be taped to a whiteboard so that the class can see them easily.

Physics Curriculum Support Document

Current and Voltage for Resistors in Series, Parallel, and Mixed Circuits: Background Information

2. Explain the basic difference between a series circuit and a parallel circuit in terms of how the light bulbs are connected in the circuit.
3. Ask students to observe the difference in the brightness of the bulbs. Ask questions, such as “Why are the bulbs in series dimmer than the bulbs in parallel?” “What do you think is happening to the current?” “What do you think is happening to the voltage drop across each bulb?”
4. At this point it is not important for the students to understand the differences between series and parallel circuits. It is only important that they are curious about the differences.
5. Let them know that the PURPOSE of these lab activities is to explore what happens to current and voltage in three different circuits and to use this information to come up with generalizations for current and voltage in these three types of circuits.

Discussion of Procedures for Collecting Data:

1. The directions for the lab are under WHAT TO DO on the student handout (see attachments). Give the students a few minutes to read this.
2. Students usually need to know two things: what the circuits will look like, and a reminder of how to connect the multimeter to measure current and voltage.
3. For each lab, draw a diagram on the board and guide students through the directions for measuring all of the currents and voltages (see attached teacher resources for clarity).
4. Clarify any questions students have about the lab.

Data Collection and Analysis:

1. Allow students to work in groups of 2 – 4 students per set up. It is worth assigning groups for this lab so that each group has a student who feels somewhat comfortable using the equipment; otherwise some groups will finish long before other groups. Data collection for the three labs can take between 40 and 90 minutes depending on the group.
2. Circulate to assist groups as needed.

Post-Lab:

1. Lab questions lead the students to the conclusions identified in the lesson goals. Depending on your class you may want to give students time in class to work together to do the calculations and answer the lab questions or it can be assigned as homework.
2. Once students have completed the lab, have students work in groups to put generalizations on white boards and explain them. Depending on the class size, six groups work fairly well. The groups can be assigned topics as follows:
 - current in series,
 - voltage in series,
 - current in parallel,
 - voltage in parallel,
 - current in mixed circuits,

Physics Curriculum Support Document

Current and Voltage for Resistors in Series, Parallel, and Mixed Circuits: Background Information

- voltage in mixed circuits.
3. If additional groups are needed due to class size, potential topics for discussion include:
 - the relationship between voltage and resistance across individual resistors in a series circuit,
 - the relationship between current and resistance of individual resistors in a parallel circuit,
 - observations about total resistance in series and parallel circuits based on the total currents in these circuits.
 4. Students present their results to the class and discuss reasons for these results.
Note: Steps 2 through 4 can also be done as a teacher led discussion.
 5. Finally, the teacher can use the conclusions the students have reached to derive the equations for total resistance in series and total resistance in parallel (see attached teacher resources for clarity).

Follow-Up:

1. Students need practice finding total resistance in a wide variety of circuits.
2. Students need practice with analyzing and solving problems for series and parallel circuits.

Challenge / Activity:

1. Have students build a circuit with three to five resistors. Depending on the ability of the students this circuit can be simple series, simple parallel or mixed. This can be done in groups or individually.
2. Have students record the voltage across the battery and the resistance of each resistor.
3. Ask students to calculate the current in one of the wires and the voltage across one of the resistors using only the voltage across the battery and the resistance of the resistors.
4. Once the calculations are done, ask the students to measure the current in that one wire and the voltage across that one resistor.
5. Students can calculate a percent difference for each value to show that they have done their math correctly. There is generally very little error in this lab – the major source of error comes from measuring the voltage of the battery when it is not connected to the resistors, causing a difference in voltage due to internal resistance of the battery.
6. Depending on time, have students do this activity more than once.

References

This activity was created by Susan Eldon (Northern High School, Durham, NC).

Physics Curriculum Support Document

Current and Voltage for Resistors in Series, Parallel, and Mixed Circuits: Background Information

Teacher Resources for Current and Voltage for Resistors in Series, Parallel, and Mixed Circuits

Current and Voltage for Resistors in Series Circuits:

Initial Diagram of Circuit:

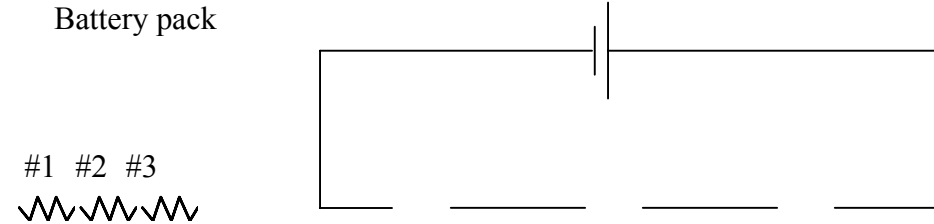
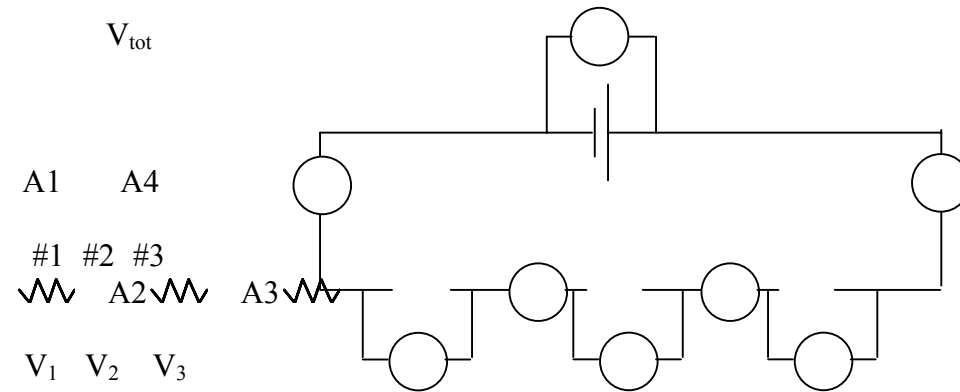

Diagram of Circuit with all Ammeter and Voltmeter Positions:



Physics Curriculum Support Document

Current and Voltage for Resistors in Series, Parallel, and Mixed Circuits: Background Information

Current and Voltage for Resistors in Parallel Circuits:

Initial Diagram of Circuit:
Battery Pack

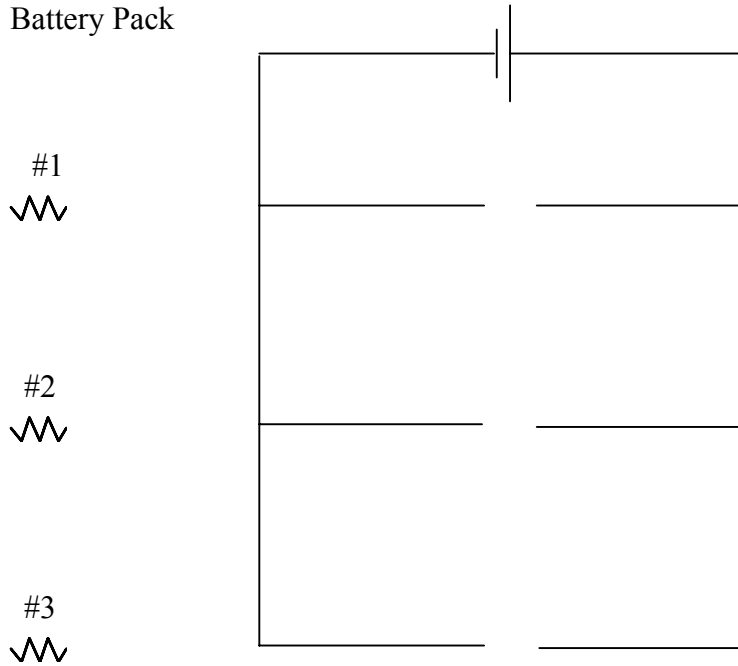
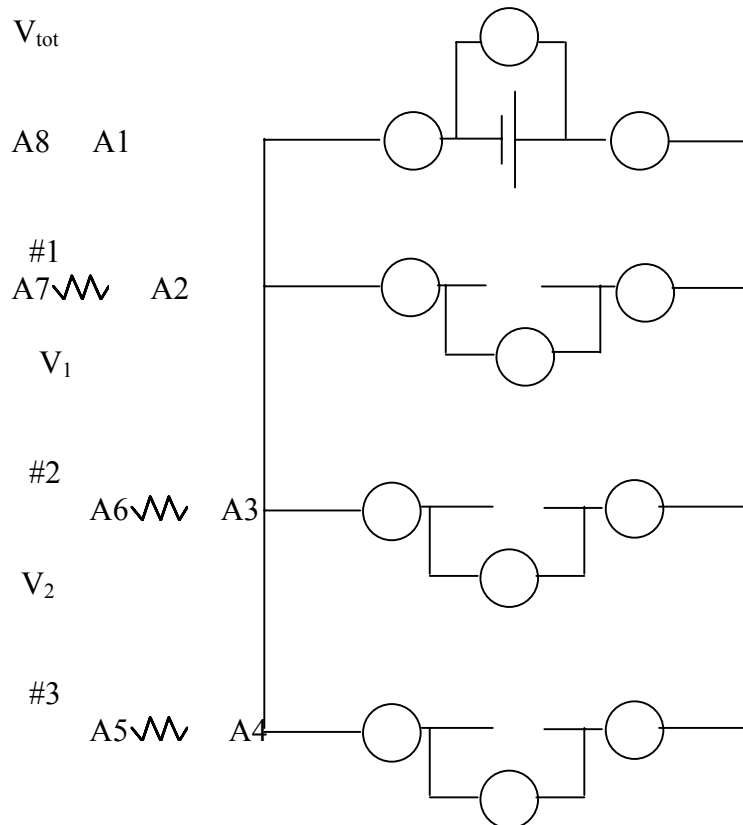

Diagram of Circuit with all Ammeter and Voltmeter Positions:



June 2007

Physics Curriculum Support Document

Current and Voltage for Resistors in Series, Parallel, and Mixed Circuits: Background Information

V_3

Current and Voltage for Resistors in Mixed Circuits

Diagram of Circuit with all Ammeter and Voltmeter Positions:

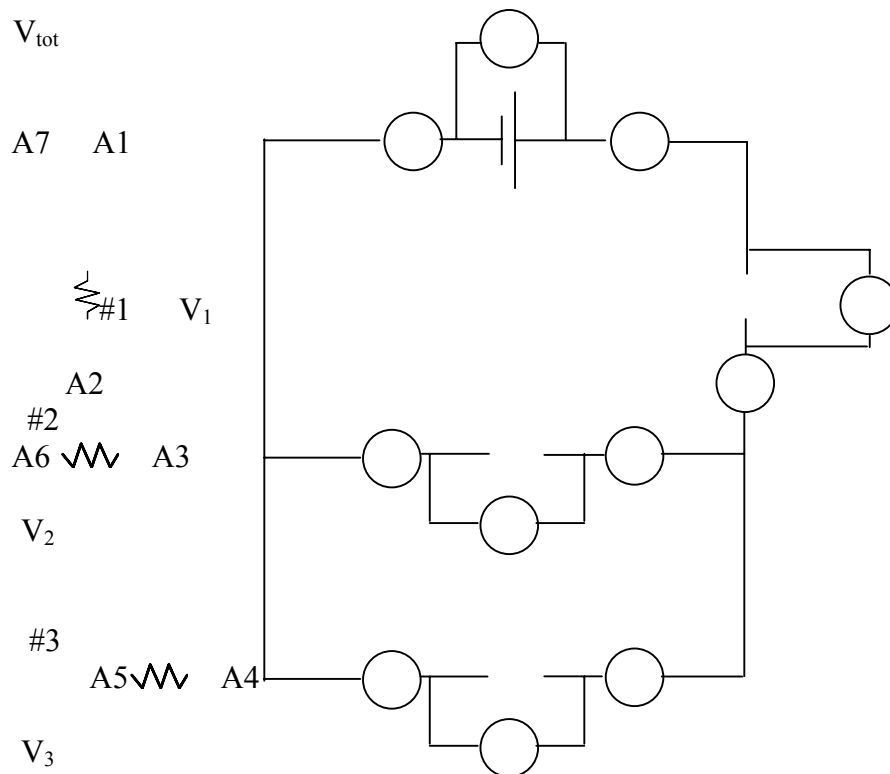

DERIVING EQUATIONS FOR TOTAL RESISTANCE:

In Series Circuits:

We know that $I_{\text{tot}} = I_1 = I_2 = I_3$ EQN 1

We also know that $V_{\text{tot}} = V_1 + V_2 + V_3$ EQN 2

We also know that $V = IR$ EQN 3

Since we are looking for total resistance, we will substitute EQN 3 into EQN 2 as follows:

$$I_{\text{tot}}R_{\text{tot}} = I_1R_1 + I_2R_2 + I_3R_3$$

But from EQN 1 we know that all of the currents are the same, so they can be cancelled.

The end result is:

June 2007

Physics Curriculum Support Document

Current and Voltage for Resistors in Series, Parallel, and Mixed Circuits: Background Information

$$R_{\text{tot}} = R_1 + \boxed{R_2 + R_3}$$

In Parallel Circuits:

We know that $V_{\text{tot}} = V_1 = V_2 = V_3$ EQN 4

We also know that $I_{\text{tot}} = I_1 + I_2 + I_3$ EQN 5

We also know that $I = V/R$ EQN 6

Since we are looking for total resistance, we will substitute EQN 6 into EQN 5 as follows:

$$V_{\text{tot}}/R_{\text{tot}} = V_1/R_1 + V_2/R_2 + V_3/R_3$$

But from EQN 4 we know that all of the voltages are the same so they can be cancelled.

The end result is:

$$1/R_{\text{tot}} = 1/R_1 + \boxed{1/R_2 + 1/R_3}$$

Physics Curriculum Support Document

Current and Voltage for Resistors in Series, Parallel, and Mixed Circuits: Laboratory

Current and Voltage for Resistors in Series, Parallel, and Mixed Circuits

Purpose

Series Circuits:

1. To recognize that current is the same throughout the circuit.
2. To recognize that voltage divides proportionally to the resistance.
3. To recognize that the sum of the voltage drops across the circuit equals the potential difference supplied to the circuit.

Parallel Circuits:

1. To recognize that current divides in inverse proportion to the resistance.
2. To recognize that the sum of the current through each device equals the current supplied to the circuit.
3. To recognize that the voltage drop across each branch is the same.

Mixed Circuits:

1. To recognize that the current entering a junction is equal to the current leaving the junction.
2. To recognize in any single path that leaves the battery and returns to the battery that the sum of the voltage drops across each device in this path is equal to the potential difference supplied to the circuit.

Materials

- Paper
- Pencil
- Calculator

Current and Voltage for Resistors in Series Circuits

Procedure

1. Obtain 1 multimeter, 1 pair of batteries, wires and three DIFFERENT resistors (not vastly different) with resistances between 10 and 150 ohms.
2. Wire up a circuit with the three resistors in series (one after the other), as discussed in class.
3. Be sure to interrupt the circuit between each reading so nothing overheats.
4. Hook up the voltmeter across the battery and record the voltage.
5. Now measure and record the voltage “ACROSS” each resistor.
6. Insert the ammeter (set on milliamps) “IN SERIES” between the wire coming from the positive terminal of the battery and the first resistor. In other words, disconnect the wire coming from the positive lead. Connect that lead to the positive end of the ammeter. Use an additional wire to connect the negative end of the ammeter to resistor #1. Read and record this value. Remove the ammeter and restore the circuit.

June 2007

Physics Curriculum Support Document

Current and Voltage for Resistors in Series, Parallel, and Mixed Circuits: Laboratory

7. Insert the ammeter in series between resistors 1 and 2. Record the value. Remove the ammeter and restore the circuit.
8. Insert the ammeter between resistors 2 and 3. Record the value. Remove the ammeter and restore the circuit.
9. Repeat again between resistor 3 and the negative terminal. Record this value.

Current and Voltage for Resistors in Parallel Circuits

Procedure

1. Obtain 1 multimeter, 1 pair of batteries, wires and three resistors that are different but not very different with resistances between 75 and 330 Ω .
2. Wire up a circuit with the three resistors in parallel (next to each other), as discussed in class.
3. Be sure to interrupt the circuit between each reading so nothing overheats.
4. Hook up the voltmeter across the battery and record the voltage.
5. Measure and record the voltage "ACROSS" each resistor.
6. Insert the ammeter "IN SERIES" between the positive terminal of the battery and the common junction. Read and record this value. Remove the ammeter and restore the circuit.
7. Now measure the current between the common junction coming from the positive terminal and each resistor. After recording each current, be sure to restore the circuit.
8. Now measure the current between each resistor and the common junction going to the negative terminal of the battery.
9. Finally measure the current between the common junction and the negative terminal of the battery.
10. When you are done you should have FOUR voltage measurements and EIGHT current measurements.

Current and Voltage for Resistors in Mixed Circuits

Procedure

1. Obtain 1 multimeter, 1 single voltage power source, wires and three resistors that are different but not very different with resistances between 60 and 250 Ω .
2. Wire a circuit that matches the circuit diagram shown in class.
3. Measure and record the voltage across the power supply and across each resistor.
4. Measure and record the total current and the current through each resistor.

Questions to Guide Analysis

Current and Voltage for Resistors in Series Circuits

1. Draw and label a schematic diagram of your circuit. Clearly label each resistor. Include all ammeter and voltmeter positions.

Physics Curriculum Support Document

Current and Voltage for Resistors in Series, Parallel, and Mixed Circuits: Laboratory

2. Indicate the color code of each resistor and its numerical value (color-color-color-color = number).

#1: _____ - _____ - _____ - _____ = _____

#2: _____ - _____ - _____ - _____ = _____

#3: _____ - _____ - _____ - _____ = _____

3. Table 1: _____

4. Table 2: _____

Voltmeter Position	Voltage (V)

Ammeter Position	Current (mA)
Average Current:	

5. Computations: **SHOW YOUR WORK!**

a. (i) Calculate the sum of the measured values for the voltage across the first, second and third resistors.

(ii) Compare against the voltage measured across the battery by doing a percent difference.

Physics Curriculum Support Document

Current and Voltage for Resistors in Series, Parallel, and Mixed Circuits: Laboratory

b. Using the voltage across each resistor and the average current through each resistor calculate the resistance of each resistor, and compare this value against the actual resistance by doing a percent error.

Calculation of Resistance:	Percent Error:
Resistor #1:	
Resistor #2:	
Resistor #3:	

6. Answer the following questions using complete sentences:

a. What do you conclude about the current in a series circuit? Base your conclusions on your data. Explain your conclusions by discussing what is happening to the charge in a circuit.

b. What do you conclude about the voltages in a series circuit? Base your conclusions on your data. Explain your conclusions by discussing the energy provided to and dissipated by the charges in the circuit.

c. What relationship appears to exist between the resistance of each resistor in the circuit and the voltage across that resistor? Base your answer on your data.

Physics Curriculum Support Document

Current and Voltage for Resistors in Series, Parallel, and Mixed Circuits: Laboratory

Current and Voltage for Resistors in Parallel Circuits

1. Draw and label a schematic diagram of your circuit. Clearly label each resistor. Include all ammeter and voltmeter positions.

2. Indicate the color code of each resistor and its numerical value (color-color-color-color = number).

#1: _____ - _____ - _____ - _____ = _____

#2: _____ - _____ - _____ - _____ = _____

#3: _____ - _____ - _____ - _____ = _____

3. Table 1: _____

Voltmeter Position	Voltage (V)

4. Table 2: _____

Ammeter Position	Current (mA)

5. Computations: **SHOW YOUR WORK!**

a. Calculate the current through each resistor by averaging the current measured before and after each resistor. Calculate the total current by averaging the current measured between the positive lead and the common junction and the current measured between the other common junction and the negative lead.

Physics Curriculum Support Document

Current and Voltage for Resistors in Series, Parallel, and Mixed Circuits: Laboratory

Current through resistor #1:	Current through resistor #2:
Current through resistor #3:	Total Current:

b. (i) Compute the sum of the currents through the three resistors using the averages.

(ii) Compare the sum against the total current by doing a percent difference.

c. Using the voltage across each resistor and the actual resistance of each resistor calculate the current through each resistor, and compare this value against the average current found above by doing a percent difference.

Calculation of Current:	Percent Difference:
Resistor #1:	
Resistor #2:	
Resistor #3:	

6. Answer the following questions using complete sentences:

a. What do you conclude about the voltages in a parallel circuit? Base your conclusions on your data. Explain your conclusions by discussing the energy provided to and dissipated by the charges in the circuit.

Physics Curriculum Support Document

Current and Voltage for Resistors in Series, Parallel, and Mixed Circuits: Laboratory

b. What do you conclude about the currents and their sums in a parallel circuit? Base your conclusions on your data. Explain your conclusions by discussing what is happening to the charges in a circuit.

c. What relationship appears to exist between the resistance of each resistor in the circuit and the current through that resistor? Base your answer on your data.

Current and Voltage for Resistors in Mixed Circuits

1. Draw and label a schematic diagram of your circuit. Clearly label each resistor. Include all ammeter and voltmeter positions.

2. Indicate the color code of each resistor and its numerical value (color-color-color-color = number).

#1: _____ - _____ - _____ - _____ = _____

#2: _____ - _____ - _____ - _____ = _____

#3: _____ - _____ - _____ - _____ = _____

3. Table 1: _____

4. Table 2: _____

Voltmeter Position	Voltage (V)

Ammeter Position	Current (mA)

5. Computations: SHOW YOUR WORK!

a. Calculate the voltage across each resistor using the measured current and the known resistance. Compare to the actual voltage across each resistor by doing a percent difference.

Physics Curriculum Support Document

Current and Voltage for Resistors in Series, Parallel, and Mixed Circuits: Laboratory

Calculation of Voltage:	Percent Difference:
Resistor #1:	
Resistor #2:	
Resistor #3:	

b. Show that the actual voltage across the two resistors in parallel are equal, by clearly recording both values and calculating a percent difference.

c. Show that the sum of the voltage across the single resistor in series and either of the two resistors in parallel is equal to the voltage across the power supply clearly recording the voltages and calculating a percent difference.

d. Show that the sum of the current through the two resistors in parallel is equal to the current through the single resistor, which is equal to the total current. Do this by clearly recording all of these values and calculating a percent difference.

Charts and References

Physics Reference Tables (2006)

Introduction

The *North Carolina Physics Reference Tables* (2006) are included in this support document on the following four pages. The purpose is to allow students and teachers to focus on understanding and applying concepts rather than memorizing equations. These reference tables are intended for students to use throughout the Physics course. Another copy of the *North Carolina Physics Reference Tables* will be provided to students when they take the End-of-Course Physics Test. Students should be given their own copy of these reference tables at the beginning of the Physics course and asked to use it frequently so that they become familiar with all of the information provided.

Careful consideration was given to the question of which variables to use to represent various quantities. Different resources such as state-adopted textbooks, AP[®] Reference Tables, and the CRC Handbook of Chemistry and Physics each use different variables for some quantities. Therefore, the variables used on the *North Carolina Physics Reference Tables* may not be the same as those used by a particular textbook. For example, gravitational potential energy is sometimes symbolized by U_g , however the *North Carolina Physics Reference Tables* use PE_g because this symbol is likely to be clearer to students.

Students should become comfortable with the variables used on the *North Carolina Physics Reference Tables* (2006) well before the End-of-Course Physics Test. Teachers can ensure this by teaching students to use the tables and making them available for a variety of classroom assessments.

Notice that the Electromagnetic Spectrum information is now presented from longest wavelength to shortest wavelength. (This reverses the presentation in the previous edition.) Mathematical relationships including some trigonometric formulas are included. (This is an addition to the previous edition.)

Students should also become proficient with the algebra skills needed to solve the equations provided for any of the variables and to use substitution to combine equations when needed.

The *North Carolina Physics Reference Tables* are available on the DPI website linked to the 2004 curriculum. Please check the web to be sure you are using the most up-to-date version.

A chart of appropriate units of measure for various quantities follows the reference table. This chart is to assist the teacher in teaching students appropriate units for the course. This information is NOT part of the *North Carolina Physics Reference Tables* and will NOT be provided for the End-of-Course Physics Test.

Physics Reference Tables

Physical Constant	Symbol	Value
Acceleration due to gravity on Earth	g	9.8 m/s/s
Coulomb's law constant	k	$9.0 \times 10^9 \frac{\text{Nm}^2}{\text{C}^2}$
Elementary charge	e	$1.6 \times 10^{-19} \text{ C}$
Electron rest mass	m_e	$9.11 \times 10^{-31} \text{ kg}$
Gravitational constant	G	$6.67 \times 10^{-11} \frac{\text{Nm}^2}{\text{kg}^2}$
Proton rest mass	m_p	$1.67 \times 10^{-27} \text{ kg}$
Speed of light in a vacuum	c	$3.00 \times 10^8 \text{ m/s}$
Speed of sound in air at STP		331 m/s

The Index of Refraction for Common Substances	
Air	1.00
Alcohol	1.36
Corn Oil	1.47
Diamond	2.42
Glass, Crown	1.52
Glass, Flint	1.61
Glycerol	1.47
Quartz, Fused	1.46
Water	1.33

Mechanics		Energy	
$\bar{v} = \frac{\Delta x}{\Delta t}$	$v = \text{velocity}$	$W = F \Delta x$	$W = \text{work}$
$x_f = x_i + vt$	$t = \text{time}$	$P = \frac{W}{\Delta t} = F \bar{v}$	$F = \text{force}$
$x_f = x_i + v_i t + \frac{1}{2} a t^2$	$x = \text{position}$		$x = \text{position}$
$a = \frac{\Delta v}{\Delta t}$	$a = \text{uniform acceleration}$	$PE_g = mgh$	$P = \text{power}$
$v_f^2 = v_i^2 + 2a\Delta x$	$F = \text{force}$	$KE = \frac{1}{2} m v^2$	$t = \text{time}$
$F = ma$	$m = \text{mass}$	$F = -kx$	$v = \text{velocity}$
$F_g = mg$	$F_g = \text{weight}$	$PE_s = \frac{1}{2} kx^2$	$PE_g = \text{gravitational potential energy}$
$F = \frac{Gm_1m_2}{d^2}$	$g = \text{acceleration due to gravity on Earth}$		$m = \text{mass}$
$F \Delta t = \Delta p = m \Delta v$	$G = \text{gravitational constant}$		$h = \text{height}$
$a_c = \frac{v^2}{r}$	$d = \text{distance between centers of mass}$		$KE = \text{kinetic energy}$
$F_c = \frac{mv^2}{r}$	$p = \text{momentum}$		$k = \text{spring constant}$
	$a_c = \text{centripetal acceleration}$		$PE_s = \text{potential energy stored in a spring}$
	$F_c = \text{centripetal force}$		
	$r = \text{radius}$		

Electricity		
$F = \frac{kq_1q_2}{d^2}$	$F = \text{force}$	Series Circuits
$V = IR$	$k = \text{Coulomb's law constant}$	$I_t = I_1 = I_2 = I_3 = \dots$
$P = VI = I^2R = \frac{V^2}{R}$	$q = \text{charge}$	$V_t = V_1 + V_2 + V_3 + \dots$
	$d = \text{distance between centers}$	$R_{eq} = R_1 + R_2 + R_3 + \dots$
	$V = \text{electrical potential difference}$	
	$I = \text{current}$	Parallel Circuits
	$R = \text{resistance}$	$I_t = I_1 + I_2 + I_3 + \dots$
	$P = \text{power}$	$V_t = V_1 = V_2 = V_3 = \dots$
		$\frac{1}{R_{eq}} = \frac{1}{R_1} + \frac{1}{R_2} + \frac{1}{R_3} + \dots$

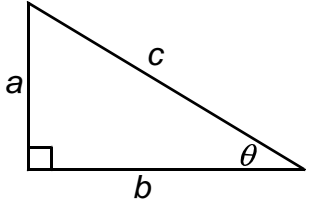
Mathematical Formulas		Wave Phenomena	
	$a^2 + b^2 = c^2$	$T = \frac{1}{f}$	$T = \text{period}$
	$\sin \theta = \frac{a}{c}$	$v = f\lambda$	$f = \text{frequency}$
	$\cos \theta = \frac{b}{c}$	$n = \frac{c}{v}$	$v = \text{speed}$
	$\tan \theta = \frac{a}{b}$	$n_1 \sin \theta_1 = n_2 \sin \theta_2$	$\lambda = \text{wavelength}$
		$\sin \theta_c = \frac{n_2}{n_1}$	$n = \text{index of refraction}$
Circumference of a circle = $2\pi r$		$n_1v_1 = n_2v_2$	$c = \text{speed of light in a vacuum}$
Area of a rectangle = length \times width			$\theta = \text{angle}$
Area of a triangle = $\frac{1}{2}$ base \times height			$\theta_c = \text{critical angle of incidence}$

Electromagnetic Spectrum (measurement in meters)

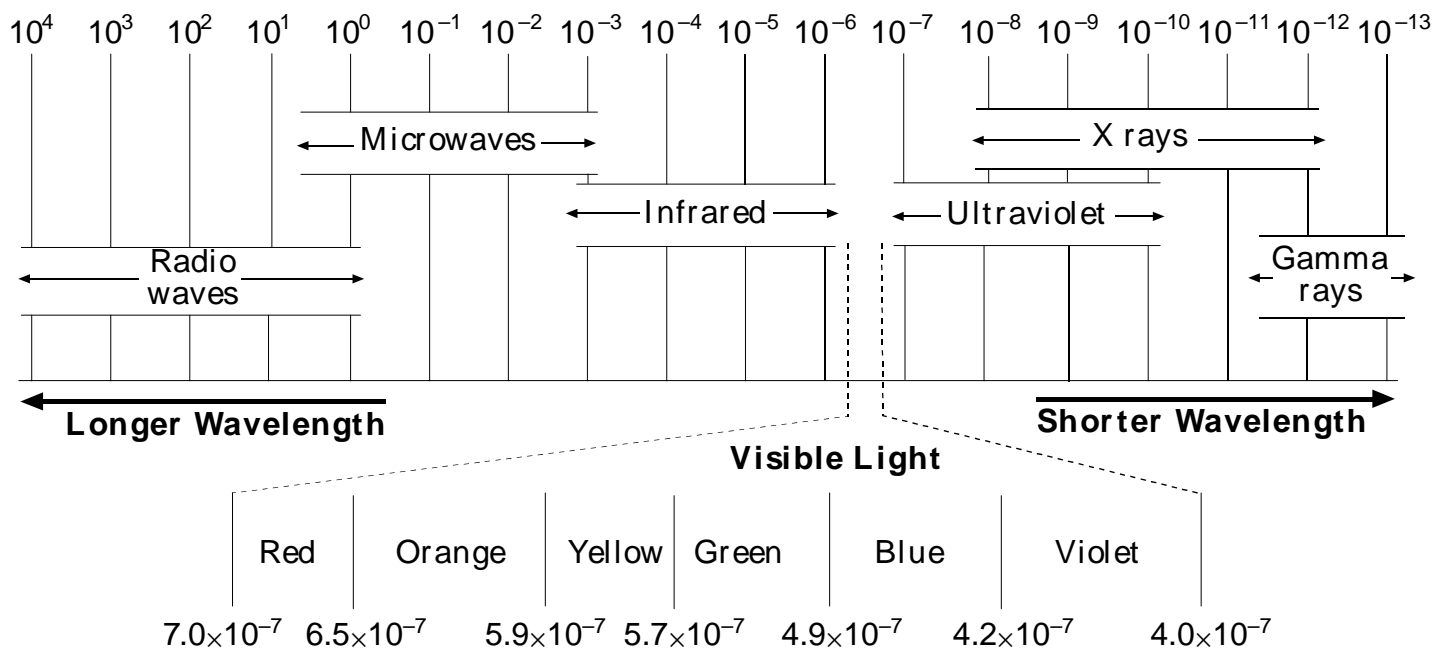

Physics Curriculum Support Document

Variables and Units of Measure

Variables and Units of Measure

This chart of variables and units of measure is provided as a **teacher** reference tool.

This chart of variables and units of measure is provided as a **teacher** reference tool.
June 2007

**Physics Curriculum Support Document
Variables and Units of Measure**

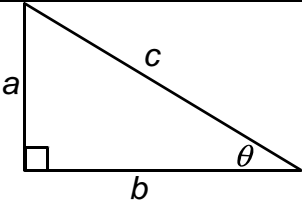
<i>Variable</i>	<i>Term</i>	<i>Possible unit</i>	<i>Equation</i>	<i>Topics</i>	<i>Comments</i>
\bar{v}	average velocity	m/s	$\bar{v} = \frac{\Delta x}{\Delta t}$	Kinematics- Goal 2 and 3	<ul style="list-style-type: none"> Other units may be used in kinematics—such as km, hr, and min. English units may also be used—such as mi, ft, and in. Students should not be expected to convert from metric to English or <i>vice versa</i>.
Δx	displacement	m			
Δt	change in time	s			
x_f	final position	m	$x_f = x_i + vt$	Kinematics- Goal 2 and 3	
x_i	initial position	m			
v	velocity	m/s			
t	time	s			
x_f	final position	m	$x_f = x_i + v_i t + \frac{1}{2}at^2$	Kinematics- Goal 2 and 3	
x_i	initial position	m			
v	velocity	m/s			
t	time	s			
a	acceleration	m/s/s			
a	acceleration	m/s/s	$a = \frac{\Delta v}{\Delta t}$	Kinematics- Goal 2 and 3	
Δv	change in velocity	m/s			
Δt	change in time	s			
v_f	final velocity	m	$v_f^2 = v_i^2 + 2a\Delta x$	Kinematics- Goal 2 and 3	
v_i	initial velocity	m			
a	acceleration	m/s/s			
Δx	displacement	m			
a	opposite side from angle θ	m		Kinematics and Dynamics- Goal 3 and 4	<ul style="list-style-type: none"> Students must master these equations in order to integrate them into their analysis of vectors.
b	adjacent side from angle θ	m			
c	hypotenuse	m			

This chart of variables and units of measure is provided as a **teacher** reference tool.
June 2007

Physics Curriculum Support Document
Variables and Units of Measure

<i>Variable</i>	<i>Term</i>	<i>Possible unit</i>	<i>Equation</i>	<i>Topics</i>	<i>Comments</i>
θ	angle for right angle triangle		$\sin \theta = \frac{a}{c}$ $\cos \theta = \frac{b}{c}$ $\tan \theta = \frac{a}{b}$		<ul style="list-style-type: none"> Note that θ does not have units.
a_c	centripetal acceleration	m/s/s	$a_c = \frac{v^2}{r}$	Centripetal motion-3.04-3.06	<ul style="list-style-type: none"> Remember that velocity is tangent to the circle. The centripetal acceleration and centripetal force vectors are perpendicular to the velocity vector and pointed toward the center of the circle.
v	velocity	m/s			
r	radius	m			
F_c	centripetal force	N	$F_c = \frac{mv^2}{r}$	Centripetal motion-3.04-3.06	
m	mass	kg			
v	velocity	m/s			
r	radius	m			
F_{net}	net force	N	$F_{net} = ma$	Dynamics-Goal 4	<ul style="list-style-type: none"> During the study of forces, it is important for students to correctly identify and draw the forces acting on an object. Force is measured in Newtons = kgm/s/s
m	mass	kg			
a	acceleration	m/s/s			
F_{net}	net force	N	$F = \frac{Gm_1m_2}{d^2}$	Dynamics-Goal 4	
m_1	mass one	kg			
m_2	mass two	kg			
G	Gravitational constant	Nm ² /kg ²			
d	distance between centers of mass	m			
F_g	weight	N	$F_g = mg$	Dynamics-Goal 4	
m	mass	kg			
g	acceleration due to gravity	m/s/s			
p	momentum	kgm/s	$p = mv$	Momentum-	

This chart of variables and units of measure is provided as a **teacher** reference tool.
June 2007

Physics Curriculum Support Document
Variables and Units of Measure

<i>Variable</i>	<i>Term</i>	<i>Possible unit</i>	<i>Equation</i>	<i>Topics</i>	<i>Comments</i>
m	mass	kg	$F\Delta t = \Delta p = m\Delta v$	Goal 5	<ul style="list-style-type: none"> The change in momentum is impulse (J). $F\Delta t=J$ The units for impulse may be $\text{kgm/s}=\text{Ns}$. Students need to look at elastic and inelastic collisions.
v	velocity	m/s			
F	force	N			
Δt	change in time	s			
Δp	momentum	kgm/s			
m	mass	kg			
Δv	change in velocity	m/s			
KE	Kinetic energy	J	$KE = \frac{1}{2}mv^2$	Energy-Goal 6	<ul style="list-style-type: none"> Students must understand that energy is always conserved. $E_i = E_f$ The unit for energy is Joule=Nm. Potential energy is also symbolized as U. Remember that work only occurs when the force applied vector is in the same direction as the displacement vector. Note that power is measured in watts=$\text{J/s}=\text{Nm/s}$. Explain to
m	mass	kg			
v	velocity	m/s			
PE_g	gravitational potential energy	J	$PE_g = mgh$	Energy-Goal 6	
m	mass	kg			
g	acceleration due to gravity	m/s/s			
h	height	m			
PE_s	potential energy stored in a spring	J	$PE_s = \frac{1}{2}kx^2$	Energy-Goal 6	
k	spring constant	N/m			
x	position	m			
F	force	N	$F = -kx$	Energy-Goal 6	
k	spring constant	N/m			
x	position	m			
W	work	J	$W = F\Delta x$	Energy-Goal 6	
F	force	N			
Δx	change in position	m			

This chart of variables and units of measure is provided as a **teacher** reference tool.
June 2007

**Physics Curriculum Support Document
Variables and Units of Measure**

<i>Variable</i>	<i>Term</i>	<i>Possible unit</i>	<i>Equation</i>	<i>Topics</i>	<i>Comments</i>
P	power	W	$P = \frac{W}{\Delta t} = F\bar{v}$	Energy-Goal 6	
W	work	J			
Δt	change in time	s			
F	force	N			
\bar{v}	average velocity	m/s			
T	period	s	$T = \frac{1}{f}$	Waves-Goal 7	<ul style="list-style-type: none"> • Note period is measured in seconds/wave. • Note that frequency is measured in Hz = waves/second • Note index of refraction does not have any units. • θ does not have any units. • c is the speed of light in a vacuum.
f	frequency	Hz			
v	speed	m/s	$v = f\lambda$	Waves-Goal 7	
f	frequency	Hz			
λ	wavelength	m			
n	index of refraction		$n = \frac{c}{v}$	Waves-Goal 7	
c	speed of light	m/s			
v	speed	m/s			
n_1	index of refraction 1		$n_1v_1 = n_2v_2$	Waves-Goal 7	
v_1	velocity in substance 1	m/s			
n_2	index of refraction 2				
v_2	velocity in substance 2	m/s			
$\theta_{\text{incidence}}$	angle for right angle triangle	law of reflection	$\theta_{\text{incidence}} = \theta_{\text{reflection}}$	Waves-Goal 7	
$\theta_{\text{reflection}}$	angle for right angle triangle				
n_1	index of refraction 1	law of refraction	$n_1 \sin \theta_1 = n_2 \sin \theta_2$	Waves-Goal 7	

This chart of variables and units of measure is provided as a **teacher** reference tool.
June 2007

**Physics Curriculum Support Document
Variables and Units of Measure**

<i>Variable</i>	<i>Term</i>	<i>Possible unit</i>	<i>Equation</i>	<i>Topics</i>	<i>Comments</i>
$\sin\theta_1$	angle for right angle triangle				
n_2	index of refraction 2				
$\sin\theta_2$	angle for right angle triangle				
$\sin\theta_c$	angle for right angle triangle		$\sin \theta_c = \frac{n_2}{n_1}$	Waves-Goal 7	
n_1	index of refraction 1				
n_2	index of refraction 2				
F	force	N	$F = \frac{kq_1q_2}{d^2}$	Electricity-Goal 8	<ul style="list-style-type: none"> • Remember that electrostatics force is a vector. • Note that potential difference is measured in volts=J/C. • Note that current is measured in Amperes=C/s. • Resistance is measured in Ω (ohms).
q_1	charge one	C			
q_2	charge two	C			
k	Gravitational constant	Nm^2/C^2			
d	distance between centers	m			
V	potential difference	V	$V = IR$	Electricity-Goal 8	
I	current	A			
R	resistance	Ω			
For Series Circuit			$I_t = I_1 = I_2 = I_3 = \dots$	Current is constant throughout the circuit.	
			$V_t = V_1 + V_2 + V_3 + \dots$	Voltage for each part is added to find the total voltage of the circuit.	

This chart of variables and units of measure is provided as a **teacher** reference tool.
June 2007

Physics Curriculum Support Document
Variables and Units of Measure

<i>Variable</i>	<i>Term</i>	<i>Possible unit</i>	<i>Equation</i>	<i>Topics</i>	<i>Comments</i>
			$R_{eq} = R_1 + R_2 + R_3 + \dots$	Resistance for each part is added to find the equivalent resistance of the circuit.	
For Parallel Circuit			$I_t = I_1 + I_2 + I_3 + \dots$	Current for each part is added to find the total current of the circuit.	
			$V_t = V_1 = V_2 = V_3 = \dots$	Voltage is constant throughout the circuit.	
			$\frac{1}{R_{eq}} = \frac{1}{R_1} + \frac{1}{R_2} + \frac{1}{R_3} + \dots$	Equivalent resistance is found by taking the inverse of the sum of the inverses of each resistor.	
P	power	W	$P = VI = I^2R = \frac{V^2}{R}$	Electricity- Goal 8	
V	potential difference	V			
I	current	A			
R	resistance	Ω			

This chart of variables and units of measure is provided as a **teacher** reference tool.
June 2007

Physics Curriculum Support Document

General Resources

Essential Resources

These resources include both this page of general resources and Goal Specific Resources starting on p. 130.

Simulation websites:

- My Physics Lab <http://www.myphysicslab.com/>
- Virtual Labs and Simulations
<http://www.hazelwood.k12.mo.us/~grichert/sciweb/applets.html>
- Educational Modules and Simulations <http://webphysics.ph.msstate.edu/jc/library/>
- Phet Physics Education Technology <http://www.colorado.edu/physics/phet/web-pages/index.html>
- University of Oregon Physics Applets <http://jersey.uoregon.edu/vlab/>

Interactive and informational:

- The Physics Classroom Multimedia Studio:
<http://www.physicsclassroom.com/mmedia/kinema/kinemaTOC.html>
- The Science Joywagon (requires a fee):
<http://www.sciencejoywagon.com/physicszone>
- LabWrite: <http://www.ncsu.edu/labwrite/>
- SASinSchool: <http://www.sasinschool.com/newiseowl/>

Assessment resources:

- New York Regents Exam prep site: <http://regentsprep.org/Regents/physics/phys-topic.cfm?Course=PHYS&TopicCode=01a>

Videos:

- Physics Cinema Classics <http://www.ztek.com/>
- Mechanical Universe <http://www.learner.org/resources/series42.html>

Data acquisition and analysis:

- Graphical Analysis and LoggerPro <http://www.vernier.com/soft/index.html>
- Graphing calculators, Excel, etc.

Physics Curriculum Support Document

General Resources

COMPETENCY GOAL 2: The learner will build an understanding of linear motion.	
<i>Objective</i>	<i>Suggested resources</i>
<p>2.01 Analyze velocity as a rate of change of position:</p> <ul style="list-style-type: none"> • Average velocity. • Instantaneous velocity. 	<ul style="list-style-type: none"> • Constant velocity with ticker timer: http://www.frontiernet.net/~jlkeefe/ho_train.htm • Physlets dealing with motion: http://webphysics.davidson.edu/physletprob/ch8_problems/ch8_1_kinematics/default.html or http://www.swgc.mun.ca/physics/physlets.html (describing motion) <p>Videos and software programs:</p> <ul style="list-style-type: none"> • Graphs and tracks software-RollBall http://dept.physics.upenn.edu/courses/gladney/mathphys/java/sect2/RollBall.html • Interactive Physics- Simulation software http://www.interactivephysics.com/description.html • Exploratorium Sport Science http://www.exploratorium.edu/sports/ • Nova- speed of sound history http://www.pbs.org/wgbh/nova/barrier/boom/concept1.html
<p>2.02 Compare and contrast as scalar and vector quantities:</p> <ul style="list-style-type: none"> • Speed and velocity. • Distance and displacement. 	<ul style="list-style-type: none"> • Vector addition lesson and gif animation: http://www.glenbrook.k12.il.us/gbssci/phys/mmedia/vectors/a_o.html • Speed Trap activity: http://www.science-house.org/teacher/empower/SpeedTrp.html
<p>2.03 Analyze acceleration as rate of change in velocity.</p>	<ul style="list-style-type: none"> • Deriving the kinematic equations http://www.physicsclassroom.com/Class/1DKin/U1L6a.html • Acceleration info: http://modeling.asu.edu/Modeling-pub/Mechanics_curriculum/3-Uniform%20a/
<p>2.04 Using graphical and mathematical tools, design and conduct investigations of linear motion and the relationships among:</p> <ul style="list-style-type: none"> • Position. • Average velocity. • Instantaneous velocity • Acceleration. • Time. 	<ul style="list-style-type: none"> • Investigation of motion: http://modeling.asu.edu/Modeling-pub/Mechanics_curriculum/3-Uniform%20a/

Physics Curriculum Support Document

General Resources

COMPETENCY GOAL 3: The learner will build an understanding of two-dimensional motion including circular motion.	
<i>Objective</i>	<i>Suggested resources</i>
3.01 Analyze and evaluate projectile motion in a defined frame of reference.	<ul style="list-style-type: none"> • Projectile motion activity: http://www.sasked.gov.sk.ca/docs/physics/u1b3phy.html
3.02 Design and conduct investigations of two-dimensional motion of objects.	<ul style="list-style-type: none"> • Independence of vectors: http://webphysics.davidson.edu/physlet_resources/semester1/c3_independence.html
3.03 Analyze and evaluate independence of the vector components of projectile motion.	<ul style="list-style-type: none"> • Projectile motion applet: http://galileo.phys.virginia.edu/classes/109N/more_stuff/Applets/ProjectileMotion/jarapplet.html
3.04 Evaluate, measure, and analyze circular motion.	<ul style="list-style-type: none"> • Circular motion animation: http://www.phy.ntnu.edu.tw/ntnujava/viewtopic.php?t=21 • Demonstrations for circular motion can be found at NCSU's demo room. Look in the section called <i>Motion in two dimensions</i>: http://demoroom.physics.ncsu.edu/html/mechanics.html
3.05 Analyze and evaluate the nature of centripetal forces.	<ul style="list-style-type: none"> • List of files on centripetal force: http://modeling.asu.edu/Modeling-pub/Mechanics_curriculum/8-UCM/
3.06 Investigate, evaluate and analyze the relationship among: <ul style="list-style-type: none"> • Centripetal force. • Centripetal acceleration. • Mass. • Velocity. • Radius. 	<ul style="list-style-type: none"> • Discussion of centripetal force: http://hyperphysics.phy-astr.gsu.edu/hbase/cf.html • Carousel: http://www.walter-fendt.de/ph14e/carousel.htm

Physics Curriculum Support Document

General Resources

COMPETENCY GOAL 4: The learner will develop an understanding of forces and Newton's Laws of Motion.	
<i>Objective</i>	<i>Suggested resources</i>
4.01 Determine that an object will continue in its state of motion unless acted upon by a net outside force (Newton's First Law of Motion, The Law of Inertia).	<ul style="list-style-type: none"> Multimedia Physics Studio discussions and animations on force topics: http://www.glenbrook.k12.il.us/gbssci/phys/mmedia/index.html The Big Misconception discussion in lesson 3 helps students identify misconception about the causes of motion: http://www.glenbrook.k12.il.us/gbssci/phys/Class/newtlaws/u2l3b.html
4.02 Assess, measure and calculate the conditions required to maintain a body in a state of static equilibrium.	<ul style="list-style-type: none"> Equilibrium info: http://www.glenbrook.k12.il.us/gbssci/phys/Class/vectors/u3l3c.html Equilibrium applet: http://www.walter-fendt.de/ph14e/equilibrium.htm
4.03 Assess, measure, and calculate the relationship among the force acting on a body, the mass of the body, and the nature of the acceleration produced (Newton's Second Law of Motion).	<ul style="list-style-type: none"> Newton's Laws discussion: http://www.glenbrook.k12.il.us/gbssci/phys/Class/newtlaws/newtlaw.html Constant force discussion: http://modeling.asu.edu/modeling-HS.html Newton's Second Law of Motion applet: http://www.walter-fendt.de/ph14e/n2law.htm
4.04 Analyze and mathematically describe forces as interactions between bodies (Newton's Third Law of Motion).	<ul style="list-style-type: none"> NASA activity on rockets: http://quest.arc.nasa.gov/space/teachers/rockets/index.html
4.05 Assess the independence of the vector components of forces.	<ul style="list-style-type: none"> Free body diagram applet: http://webphysics.davidson.edu/physlet_resources/semester1/c5_fbd1.html
4.06 Investigate, measure, and analyze the nature and magnitude of frictional forces.	<ul style="list-style-type: none"> Frictional force: http://www.phy.ntnu.edu.tw/ntnujava/viewtopic.php?t=18
4.07 Assess and calculate the nature and magnitude of gravitational forces (Newton's Law of Universal Gravitation).	<ul style="list-style-type: none"> Universal Gravitation experiment described with movie clips showing the equipment http://www.phys.unsw.edu.au/hsc/space.html

Physics Curriculum Support Document

General Resources

COMPETENCY GOAL 5: The learner will build an understanding of impulse and momentum.	
<i>Objective</i>	<i>Suggested resources</i>
5.01 Assess the vector nature of momentum and its relation to the mass and velocity of an object.	<ul style="list-style-type: none"> Introduction to momentum: http://id.mind.net/~zona/mstm/physics/mechanics/momentum/introductoryProblems/momentumSummary1.html
5.02 Compare and contrast impulse and momentum.	<ul style="list-style-type: none"> Impulse sports connection: http://sportsfigures.espn.com/sportsfigures/lp_relaxingImpulse.jsp?iAm=null
5.03 Analyze the factors required to produce a change in momentum.	<ul style="list-style-type: none"> Ranking tasks on impulse and change in momentum: http://cwx.prenhall.com/bookbind/pubbooks/giancoli3/chapter9/destinations2/deluxe-content.html
5.04 Analyze one-dimensional interactions between objects and recognize that the total momentum is conserved in both collision and recoil situations.	<ul style="list-style-type: none"> The Physics Classroom is a great alternative to a text book: http://www.physicsclassroom.com/Class/momentum/momtoc.html The Modeling Physics resources can be found at the Arizona State University Modeling site: http://modeling.asu.edu/Curriculum.html The ExploreScience Virtual Air Track allows students to explore collisions online: http://www.hazelwood.k12.mo.us/~grichert/explore/dswmedia/airtrack.htm A Momentum Physlet-Based Curriculum is available: http://webphysics.davidson.edu/physletprob/ch8_problems/ch8_5_momentum/default.html
5.05 Assess real world applications of the impulse and momentum, including but not limited to, sports and transportation.	<ul style="list-style-type: none"> Real world applications: http://www.glenbrook.k12.il.us/gbssci/phys/Class/momentum/u411c.html
COMPETENCY GOAL 6: The learner will develop an understanding of energy as the ability to cause change.	
<i>Objective</i>	<i>Suggested resources</i>
6.01 Investigate and analyze energy storage and transfer mechanisms: <ul style="list-style-type: none"> Gravitational potential energy. Elastic potential energy. Thermal energy. Kinetic energy. 	<ul style="list-style-type: none"> Gravitational potential energy applet: http://jersey.uoregon.edu/vlab/PotentialEnergy/index.html Spring potential energy information: http://id.mind.net/~zona/mstm/physics/mechanics/energy/springPotentialEnergy/springPotentialEnergy.html Thermal energy info: http://en.wikipedia.org/wiki/Thermal_energy Kinetic energy applet: http://jersey.uoregon.edu/vlab/KineticEnergy/index.html

Physics Curriculum Support Document

General Resources

COMPETENCY GOAL 6: The learner will develop an understanding of energy as the ability to cause change.	
<i>Objective</i>	<i>Suggested resources</i>
6.02 Analyze, evaluate, and apply the principle of conservation of energy.	<ul style="list-style-type: none"> Energy transformations applet: http://www.glenbrook.k12.il.us/gbssci/phys/mmedia/energy/se.html
6.03 Analyze, evaluate, and measure the transfer of energy by a force. <ul style="list-style-type: none"> • Work. • Power. 	<ul style="list-style-type: none"> Power info: http://www.physicsclassroom.com/Class/energy/U5L1e.html Work-energy info: http://www.physicsclassroom.com/Class/energy/U5L2a.html
6.04 Design and conduct investigations of: <ul style="list-style-type: none"> • Mechanical energy. • Power. 	<ul style="list-style-type: none"> Energy transformations on roller coasters: http://www.glenbrook.k12.il.us/gbssci/phys/mmedia/energy/ce.html Activity to brainstorm energy transformations: http://www.hypertextbook.com/physics/mechanics/energy/
COMPETENCY GOAL 7: The learner will develop an understanding of wave motion and the wave nature of sound and light.	
<i>Objective</i>	<i>Suggested resources</i>
7.01 Analyze, investigate, and evaluate the relationship among the characteristics of waves: <ul style="list-style-type: none"> • Wavelength. • Frequency. • Period. • Amplitude. 	<ul style="list-style-type: none"> General wave information: http://www.glenbrook.k12.il.us/gbssci/phys/Class/waves/wavestoc.html Parts of a wave: http://id.mind.net/~zona/mstm/physics/waves/partsOfAWave/waveParts.htm
7.02 Describe the behavior of waves in various media.	<ul style="list-style-type: none"> Wave reflection at boundaries applet: http://id.mind.net/~zona/mstm/physics/waves/waveReflection/waveReflection.html
7.03 Analyze the behavior of waves at boundaries between media: <ul style="list-style-type: none"> • Reflection, including the Law of Reflection. • Refraction, including Snell's Law. 	<ul style="list-style-type: none"> Light reflection: http://id.mind.net/~zona/mstm/physics/light/rayOptics/reflection/reflection1.html Light refraction: http://id.mind.net/~zona/mstm/physics/light/rayOptics/refraction/refraction1.html
7.04 Analyze the relationship between the phenomena of interference and the principle of superposition.	<ul style="list-style-type: none"> Superposition applet: http://courses.ncssm.edu/physics/physlets/WAVES/wavesapplet.htm Interference info: http://id.mind.net/~zona/mstm/physics/waves/interference/intrfnc.html

Physics Curriculum Support Document

General Resources

COMPETENCY GOAL 7: The learner will develop an understanding of wave motion and the wave nature of sound and light.	
<i>Objective</i>	<i>Suggested resources</i>
7.05 Analyze the frequency and wavelength of sound produced by a moving source (the Doppler Effect).	<ul style="list-style-type: none"> Info on Doppler Effect: http://en.wikipedia.org/wiki/Doppler_effect
COMPETENCY GOAL 8: The learner will build an understanding of static electricity and direct current electrical circuits.	
<i>Objective</i>	<i>Suggested resources</i>
8.01 Analyze the nature of electrical charges. <ul style="list-style-type: none"> Investigate the electrical charging of objects due to transfer of charge. Investigate the conservation of electric charge. Analyze the relationship among force, charge and distance summarized in Coulomb's law. 	<ul style="list-style-type: none"> Electroscope applet: http://www.shep.net/resources/curricular/physics/P30/Unit2/electroscope.html Static electricity misconceptions: http://amasci.com/emotor/stmiskon.html
8.02 Analyze and measure the relationship among potential difference, current, and resistance in a direct current circuit.	<ul style="list-style-type: none"> Water circuit analogy to electric circuit: http://hyperphysics.phy-astr.gsu.edu/hbase/electric/watcir.html Ohm's Law discussion: http://micro.magnet.fsu.edu/electromag/java/ohmslaw/
8.03 Analyze and measure the relationship among current, voltage, and resistance in circuits. <ul style="list-style-type: none"> Series. Parallel. Series-parallel combinations. 	<ul style="list-style-type: none"> Voltage Circuit Simulator: http://jersey.uoregon.edu/vlab/Voltage/ Applet that allows exploration of different circuits: http://lectureonline.cl.msu.edu/~mmp/kap20/RR506a.htm
8.04 Analyze and measure the nature of power in an electrical circuit.	<ul style="list-style-type: none"> Electric power article: http://www.school-for-champions.com/science/electpower.htm

Physics Curriculum Support Document

Appendix: Units of Measure

Physics Curriculum Comparison

Big Idea	Adopted 1999	Adopted 2004
Inquiry Skills	Introduction and Strands	Goal 1
	Note for inquiry skills: <i>The inquiry skills will be integrated into each of the other goals.</i>	
Motion	Linear Motion	
	Goal 1 Objective 1.01	Goal 2 Objective 2.01
	Goal 1 Objective 1.02	Goal 2 Objective 2.02
	Goal 1 Objective 1.03	Goal 2 Objective 2.04 3 rd bullet
	Goal 1 Objective 1.04	Goal 2 Objective 2.03
	Goal 1 Objective 1.05	Goal 2 Objective 2.04
	Note for scalar and vector quantities: <i>Distance and displacement will be clarified in an additional bullet for 2004 objective 2.02.</i>	
	Note for graphical and mathematical tools: <i>2004 objective 2.04 has been reworded to incorporate Goal 1.</i>	
	Two-Dimensional Motion	
	Goal 2 Objective 2.01	Goal 3 Objective 3.01
	Introduction and Strands	Goal 3 Objective 3.02—design and conduct investigations
	Goal 2 Objective 2.02 and 2.03 –includes vector components	Goal 3 Objective 3.03
	Goal 2 Objective 2.04	Goal 3 Objective 3.04
	Goal 2 Objective 2.01	Goal 3 Objective 3.01
	Goal 3 Objective 3.04	Goal 3 Objective 3.05, 3.06
Note for investigations of two-dimensional motion: <i>2004 objective 3.02 will show the importance of designing and conducting experiments to investigate two-dimensional motions.</i>		
Note for two-dimensional motion: <i>The focus in 2004 objectives 3.01, 3.02, and 3.03 will be on projectile motion.</i>		
Note for circular motion: <i>Circular motion and centripetal forces will be consolidated in 2004 Goal 3. This topic should be taught after 2004 Goal 4.</i>		
Forces	Goal 3 Objective 3.01	Goal 4 Objective 4.02
	Goal 3 Objective 3.02	Goal 4 Objective 4.07
	Goal 3 Objective 3.03	Goal 4 Objective 4.06-including investigate frictional forces
	Goal 3 Objective 3.04	Goal 4 Objective 3.05 and 3.06
	Goal 4 Objective 4.01	Goal 4 Objective 4.01
	Goal 4 Objective 4.02	Goal 4 Objective 4.03
	Goal 4 Objective 4.03	Goal 4 Objective 4.04
		Goal 4 Objective 4.05

Physics Curriculum Support Document

Appendix: Units of Measure

Big Idea	Adopted 1999	Adopted 2004
	<p>Note for forces: 1999 Goals 3 and 4 will be combined into 2004 Goal 4.</p> <p>Note for vector components: The independence of vector components of forces will be added as a separate objective.</p> <p>Note for static equilibrium: The focus of the 2004 curriculum will be on objects as point masses; thus torque is not required for the core curriculum.</p> <p>Note for friction: Although friction is still included, the concept of coefficient of friction is not required for the core curriculum.</p>	
Momentum	Goal 6 Objective 6.01	Goal 5 Objective 5.01
	Goal 6 Objective 6.02	Goal 5 Objective 5.02
	Goal 6 Objective 6.03	Goal 5 Objective 5.03
	Goal 6 Objective 6.04	Goal 5 Objective 5.04
	Goal 6 Objective 6.05 –including analyzing the factors required to produce a change in momentum	Goal 5 Objective 5.05 –including assessing real world applications of impulse and momentum
	<p>Note for momentum conservation: The core curriculum will be limited to one-dimensional interactions.</p> <p>Note for application of momentum: Applications of impulse and momentum will be added to the core curriculum as 2004 objective 5.05.</p>	
Energy	Goal 5 Objective 5.01 –includes gravitational potential energy and elastic potential energy Goal 5 Objective 5.02 –includes kinetic energy Goal 8 –includes temperature, thermal energy, first law of thermodynamics, and second law of thermodynamics	Goal 6 Objective 6.01 –includes gravitational potential energy, elastic potential energy, thermal energy, and kinetic energy
	Goal 5 Objective 5.03	Goal 6 Objective 6.02
	Goal 5 Objective 5.04	Goal 6 Objective 6.03
	Introduction and Strands	Goal 6 Objective 6.04—design and conduct investigations
	<p>Note for energy: A shift in emphasis will be from forms of energy to energy storage and transfer mechanisms.</p> <p>Note for thermal energy: The focus will be greatly reduced. Thermal energy will be found as a bullet in 2004 objective 6.01 instead of a separate goal. The focus will be on thermal energy as a method of energy storage. Thermodynamics will no longer be a part of the core physics curriculum. It will be in the chemistry curriculum.</p> <p>Note for power: Power will be included as a separate bullet in 2004 objective 6.03.</p>	
	Goal 7 Objective 7.01	Goal 7 Objective 7.01
	Goal 7 Objective 7.02	Goal 7 Objective 7.02
Waves	Goal 7 Objective 7.03	Goal 7 Objective 7.03
	Goal 7 Objective 7.04	
	Goal 7 Objective 7.05	Goal 7 Objective 7.04
	Goal 7 Objective 7.06	Goal 7 Objective 7.05

Physics Curriculum Support Document

Appendix: Units of Measure

Big Idea	Adopted 1999	Adopted 2004
	<p>Note for Law of Reflection and Snell's Law: <i>Law of Reflection and Snell's Law will be added to the bullets for reflection and refraction.</i></p> <p>Note for optics: <i>Geometric optics (curved mirrors and lenses) is no longer a part of the 2004 core curriculum.</i></p> <p>Note for diffraction: <i>Diffraction will be removed from the 2004 core curriculum.</i></p>	
Electricity	Goal 9 Objective 9.01 and Objective 9.02	Goal 8 Objective 8.01 –including transfer of charge, conservation of charge and Coulomb's law
	Goal 9 Objective 9.03	
	Goal 10 Objective 10.01	Goal 8 Objective 8.02
	Goal 10 Objective 10.02	Goal 8 Objective 8.03
	Goal 10 Objective 10.03	Goal 8 Objective 8.04
	<p>Note for combination circuits: <i>2004 objective 8.03 clarifies that series-parallel combination circuits are a part of the curriculum.</i></p> <p>Note for moving charges and magnetic fields: <i>This topic will be removed from the 2004 core curriculum.</i></p>	

Physics Curriculum Support Document

Alternative sequencing schemes for physics

Alternative sequencing schemes for physics

Alternative sequencing schemes are provided to show several possible ways of organizing the course and approximate recommended amounts of time to spend on the different topics. Other sequences are certainly possible. Pacing guides are **not** provided because the detail that makes a useful pacing guide depends on local factors such as what materials and resources you have available for laboratories and activities, available textbooks, how you choose to integrate topics and themes, whether materials are shared across classrooms, your local calendar, etc. etc.

Sequencing Scheme I (based on a 90 day class)

Days	Unit	Topics
12	1 D Kinematics	Distance, position, velocity, speed, and acceleration
15	2 D Kinematics	Frame of reference, vectors, projectile motion, and circular motion
15	Forces	Inertia, force, mass, weight, Newton's laws of motion, friction, and centripetal force
15	Energy	Kinetic energy, potential energy, gravitational potential energy, elastic energy, thermal energy, work, conservation of energy, and power
10	Momentum	Momentum, impulse, and conservation of momentum
10	Waves	Waves, sound waves, mechanical waves, electromagnetic waves, reflection, refraction, and Doppler effect
13	Electricity	Static electricity, Ohm's law, current electricity, series circuits, parallel circuits, and power

Physics Curriculum Support Document

Alternative sequencing schemes for physics

Sequencing Scheme II (based on a 180 day class)

Days	Unit	Topics
30	Kinematics	Distance, position, velocity, speed, acceleration, frame of reference, vectors, projectile motion, and circular motion
30	Forces	Inertia, force, mass, weight, Newton's laws of motion, friction, and centripetal force
30	Momentum	Momentum, impulse, and conservation of momentum
25	Energy	Kinetic energy, potential energy, gravitational potential energy, elastic energy, thermal energy, work, conservation of energy, and power
20	Waves	Waves, sound waves, mechanical waves, electromagnetic waves, reflection, refraction, and Doppler effect
25	Electricity	Static electricity, Ohm's law, current electricity, series circuits, parallel circuits, and power

Physics Curriculum Support Document

Bibliography

Bibliography

Chabay, R., & Sherwood, B. (1995). *Electric and magnetic interactions*. New York: John Wiley and Sons.

Morse, R. (1992). *Teaching about electrostatics aapt/ptra-plus workshop*. College Park, MD: American Association of Physics Teachers.

National Research Council. (1996). *National Science Education Standards*. Washington, D.C.: National Academy Press.

Trinklein, F. (1990). *Modern Physics*. : Holt, Rinehart and Winston.

Zitsewitz, P. (2002). *Physics Principles and Problems*. : Glencoe/McGraw Hill.

Honors Physics Curriculum Support Document

Curriculum Support For the 2004 revision of the *North Carolina Standard Course of Study for Honors Physics*

Acknowledgements

A group of dedicated and talented science educators spent many hours developing these materials. The result is a resource that will facilitate the implementation of the North Carolina Science Curriculum.

A special thanks to the authors of these materials:

Pamela Lovin, Physics Curriculum Committee Chairperson
Steve Brown, South Granville High School
David English, Northside High School
Kerry Havner, North Carolina State University
Scott Rogers, A.L. Brown High School
Justin Rondash, North Brunswick High School
Laura Rumbley, Jacksonville High School
Jean Tripp, Roanoke Rapids High School
Bill Tucci, Director of K-12 Educational Programs, Kenan Institute
And to the many other teachers and scientists who provided helpful comments.

Comments on these materials should be addressed to:

Eleanor Hasse
High School Science Section
North Carolina Department of Public Instruction
301 North Wilmington Street
Raleigh, NC 27601-2825
Email: eehasse@dpi.state.nc.us

Honors Physics Curriculum Support Document

Honors Courses in North Carolina: Science

Honors Science Courses

All of the honors science courses share the following characteristics and assumptions:

- Students enrolled in honors courses will learn the material in the standard course of study for the course at greater depth than in the standard level version of the course. The support documents for the course include appropriate honors extensions by objective.
- Students enrolled in the honors version of the course will take the same EOC as students enrolled in the standard level version of the course.
- Students who choose an honors science course are expected to work more independently than students in standard level courses.
- Because students can be expected to cover the standard level material more independently there will be time for more enrichment topics as specified in the course descriptions for specific honors courses.
- Students who choose an honors science course will be expected to complete more independent in-depth scientific investigations and to report on them using a more formal scientific laboratory report format.
- Students who choose an honors science course will be expected to read about recent scientific research and present their findings orally and in writing.

Many of the materials and activities suggested for honors courses will also be appropriate for some students enrolled in standard level versions of the course. The difference may be in the level of independence expected of students and the amount of time activities may take. All students, not just those in honors courses, should experience challenging work and some level of independent inquiry in their science courses. Teachers should include some of the enrichment topics for all students.

Definition of Honors Science Courses

Honors science courses are designed to demand more challenging involvement than standard science courses. They must be demonstrably more challenging than standard courses and provide multiple opportunities for students to take greater responsibility for their learning. Honors science courses should be distinguished by a difference in the quality of the work expected rather than merely by the quantity of the work required.

Purposes of Honors Science Courses

Honors science courses should be designed for students who have demonstrated an advanced level of interest and achievement in a given subject area. The rationale for honors courses is not to provide a means to attract students to enroll in classes for additional credit, but rather to offer challenging, higher level courses for students who aspire to an advanced level of learning. Furthermore, students and parents should be informed that honors science courses are more demanding and have requirements beyond those of standard science courses.

Honors Physics Curriculum Support Document

Honors courses should be developed as an integral component of a differentiated program of study that provides an array of opportunities for all students based on their aptitudes, affinities, and interests.

Scheduling Honors Science Courses and Standard Level Courses Together

Honors and standard levels may be offered in the same classroom simultaneously when necessary. For example, a small school with limited physics enrollment may find it necessary to combine these two groups of students for instruction. Teachers in this position will need to put special emphasis on appropriate differentiation in their planning. Professional development with a focus on differentiation is recommended in this case.

Characteristics of Honors Science Courses

Honors science courses will address the same goals and objectives as the corresponding *NC Standard Course of Study*; however, they should address the content with greater complexity, novelty, acceleration, and/or pacing. Honors science courses should reflect a differentiation of curriculum, both in breadth and depth of study. Honors science courses should exemplify the following characteristics:

- Require a higher level of cognition and quality of work than the standard course
- Enable students to become actively involved in classroom and laboratory learning experiences
- Involve students in exploratory, experimental, and open-ended learning experiences

Honors science courses should provide opportunities for the following:

- Problem-seeking and problem-solving
- Participation in scholarly and creative processes
- Use of imagination
- Critical analysis and application
- Personalized learning experiences
- Learning to express/defend ideas
- Learning to accept constructive criticism
- Becoming a reflective thinker
- Becoming an initiator of learning

Essential Questions

Essential questions are designed to focus attention on main ideas. They are used in honors courses to prompt thinking and spark discussion of key elements within a larger context. Essential questions are helpful in working through the steps in problem-solving, planning, and decision making processes.

Essential questions reflect the most historically important issues, problems and debates in a field of study. In the sciences, essential questions should be used to help students make connections across particular disciplines such as biology and chemistry to the larger unifying concepts of science as well as to focus on essential questions within disciplines. For example, “What factors affect the motion of objects?”, “How can we represent these factors?” and “How can we combine the various factors to predict motion?” are essential

Honors Physics Curriculum Support Document

questions within Physics. “What other explanations could account for this data?” and “How can we measure that?” are essential questions in all of the sciences. By examining such questions, students engage in higher order thinking. Essential questions are open-ended with no single, correct answer.

Essential questions are meant to stimulate inquiry, debate and further questions, and can be reexamined over time. They are designed to be thought provoking to students, engaging them in sustained, focused inquiries, culminating in meaningful performances (McTighe & Wiggins, 2004).

Instructors of honors science courses are expected not only to pose essential questions to the students, but also to guide students in generating their own essential questions. The Honors Science Portfolio should include a list of essential questions with specific indications of how these essential questions are to be used in the honors class.

Honors Physics Curriculum Support Document

Introduction to Honors Physics

These materials were developed to assist in the development and implementation of Honors Physics courses. It should be noted, however, that **this document is not an honors teaching portfolio**. Each individual LEA and/or honors physics teacher needs to create a portfolio to document their own honors physics course. The materials included in this document are sample activities and suggestions provided to help in the portfolio development process. Honors courses may be developed at the LEA, school or teacher level. A local review and monitoring process should be put in place. As teachers develop their honors portfolios, they should use this opportunity to document what they are already doing well, while further developing the rigor in their courses. This should be seen as an on-going process. Courses should be revised and reviewed each year.

Essential Questions: Essential questions may be organized by teaching units rather than by the *Standard Course of Study*. Their purpose is to help focus teachers and students on the most important or essential concepts. Often an essential question bridges between objectives or serves as an organizing question for a unit that brings in concepts from several goals and objectives. Some essential questions will recur throughout the course. Sometimes after writing the overarching question, teachers will need to consider "entry point" questions to help students do the research and understand the background to access the topic at a higher level. Below are some internet resources related to essential questions.

http://www.myprojectpages.com/support/ess_questpopup.htm

http://www.essentialschools.org/cs/resources/view/ces_res/137

<http://members.tripod.com/~ozpk/0000000EQ> - this page starts with an assortment of links to other essential question sites and then has some examples - the ones in this site will help teachers make interdisciplinary connections beyond the sciences.

Precautions:

- **All students**, not just those in honors courses, should experience challenging work and some level of independent inquiry in their courses.
- Many of the materials and activities suggested for honors courses will also be appropriate for some students enrolled in standard level versions of the course.
- Teachers should include some of the enrichment topics for all students.
- **Independent does not mean unsupervised!**
 - Teachers must still provide appropriate supervision at all stages.
 - For independent projects teachers should give choices of topics or have a process in place for topic review and approval.
 - Teachers should always review project design carefully for safety reasons and to be sure the project will provide an appropriate learning experience.

Honors Physics Curriculum Support Document

- Actual laboratory work must be supervised. Younger and less experienced students will need more scaffolding to make this a productive learning experience.
- Independent **DOES** mean that the teacher will **NOT** provide all of the structure and step by step instructions.
- **Independent does not mean alone or unsupported!**
 - Just as adults in all sorts of industries usually work in teams, students may also work in teams.
 - Teachers may need to provide some assistance to students in finding appropriate sources and models of appropriate performances.

A more extensive introduction to the development of honors courses is in the *Honors Course Implementation Guide* available for download at <http://www.ncpublicschools.org/curriculum/honorsguide>

Honors Physics Curriculum Support Document

Honors Physics Course Description

Course Code 3060

Honors Physics uses the *North Carolina Standard Course of Study* for Physics as a foundation for more challenging and advanced study that enriches key topics and broadens the student's view of the larger physics community including current research. Teachers will increase the depth of each topic specified in the *Standard Course of Study* for Physics. Substantial class time should be devoted to student-directed exploration and experimentation. All honors science courses must include an independent student investigation component. In addition to the goals and objectives specified in the *Standard Course of Study*, teachers should include an in-depth study of **at least two** of the following enrichment topics: engineering, thermodynamics, nuclear energy, optics, electromagnetism, or modern physics. Sample objectives for these topics are provided below.

Honors Physics is an appropriate course for students with a strong mathematics and science background. Success in Honors Physics will require the student to: 1) operate with algebraic expressions to solve complex equations which include trigonometric functions, 2) use exponents to solve problems, and 3) describe graphically, algebraically and verbally real-world phenomena as functions and identify independent and dependent variables.

High school physical science is NOT a required prerequisite for this course. The Physics End-of-Course test is required to receive honors physics credit. Students may not take Honors Physics in addition to standard level *Standard Course of Study* Physics.

Additional Objectives for Honors Physics

1.06H Design, conduct, and evaluate scientific investigations of physics phenomena.

- Verify student generated hypothesis through independent inquiry activities over time.
- Assess possible sources of error and ways to improve the investigation.
- Explain scientific processes and analysis in formal writing on a continuing basis.
- Assess the relevance of physics phenomena to real world scenarios and recent research.
- Summarize the results of scientific investigations and/or research to the larger community, including but not restricted to other students, parents, and community groups.

1.07 H Design and conduct investigations using engineering skills.

6.05 H Evaluate thermodynamic processes with the laws of thermodynamics.

6.06 H Evaluate nuclear energy as a storage and transfer mechanism.

7.06 H Design and conduct investigations of optics (mirrors and lenses) and the laws of reflection and refraction.

Honors Physics Curriculum Support Document

8.05 H Analyze the relationship between moving electric charges and magnetic fields (electromagnetism).

8.06 H Analyze and mathematically describe relationships within modern physics such as the Quantum Theory and study of the Atom.

Suggestions for Honors Physics

This section is designed to contain a list of suggestions to help in implementing an Honors Physics course. The suggestions may involve labs, classroom management, or other activities integral for productive class.

Laboratory

- Make the course visible throughout the school. Conduct labs in the cafeteria, lobby, gym, library, and even outside. This will demonstrate the excitement in physics to other students in the school.
- Ask students to keep two lab books. The students can alternate doing labs in each notebook. This way a lab may be conducted, while another lab is being graded.

Outdoor lab activities

- Use the fire drill route to exit the building for all outside laboratory activities. This will familiarize the students with the proper exit route and it will become second nature.
- Be aware of allergies the students may have, especially bee allergies when working outside.

Projects

- Create projects around state and national competitions. This will provide the opportunity for students to participate in competitions. This will help many college and scholarship applications and provide an external reason for doing well on the project.
- Allow speakers and scientists to judge projects using teacher-developed rubric. The speakers may then give out the awards for excellence.

Honors Physics Curriculum Support Document

Just Do It: Background Information

Just Do It

Targeted *Standard Course of Study* Goals and Objectives:

- **COMPETENCY GOAL 1: The learner will develop abilities necessary to do and understand scientific inquiry.**
 - 1.06H
 - 1.07H,
- **COMPETENCY GOAL 2: The learner will build an understanding of linear motion.**
- **COMPETENCY GOAL 3: The learner will build an understanding of two-dimensional motion including circular motion.**
- **COMPETENCY GOAL 4: The learner will develop an understanding of forces and Newton's Laws of Motion.**
- **COMPETENCY GOAL 5: The learner will build an understanding of impulse and momentum.**
- **COMPETENCY GOAL 6: The learner will develop an understanding of energy as the ability to cause change**

Essential Question(s):

How has current technology extended the limits of human performance?

- How are mathematical models used to represent motion?
- How are mathematical models used to represent forces?
- How are vectors used in describing motion?

Introduction to the Teacher:

This project uses the student's interest in sports to relate physics to a real world scenario and employ recent research. The students will select and analyze an athletic activity. The project will include: (1) research historical development and technological advancements in the activity (2) design a scientific investigation to analyze the activity (3) summarize the results of the scientific investigation(s) and/or research to a larger community. Probable topics of study include motion, forces, impulse, momentum, vectors, energy transfer, and projectiles.

Differentiation from Standard-level:

The project is an independent research experience of physics in a more abstract and quantitative level than the standard-level physics. Honors students will design their own experiment(s), produce an abstract and/or laboratory report, and produce a tangible, curriculum product. The project could be used in a more teacher-directed fashion or the presentations from the honors project could be used by the standard-level to experience the physics phenomena.

Honors Physics Curriculum Support Document

Just Do It: Background Information

Safety/Special Considerations:

Teachers should ensure that students are well versed in standard laboratory safety procedures. Teachers need to approve the topics, required materials and experimental design of the project. Teachers should refer to the NC Total Science Safety System software for specific guidelines.

References:

North Carolina Standard Course of Study
Honors Courses in North Carolina: Science

Honors Physics Curriculum Support Document

Just Do It: Laboratory

Just Do It

Targeted *Standard Course of Study* Goals and Objectives:

- **COMPETENCY GOAL 1: The learner will develop abilities necessary to do and understand scientific inquiry.**
 - 1.06H
 - 1.07H,
- **COMPETENCY GOAL 2: The learner will build an understanding of linear motion.**
- **COMPETENCY GOAL 3: The learner will build an understanding of two-dimensional motion including circular motion.**
- **COMPETENCY GOAL 4: The learner will develop an understanding of forces and Newton's Laws of Motion.**
- **COMPETENCY GOAL 5: The learner will build an understanding of impulse and momentum.**
- **COMPETENCY GOAL 6: The learner will develop an understanding of energy as the ability to cause change**

Essential Question(s):

How has current technology extended the limits of human performance?

- How are mathematical models used to represent motion?
- How are mathematical models used to represent forces?
- How are vectors used in describing motion?

Introduction:

Physics is can be used to study the world of sports. Sports equipment and mechanics is heavily influenced by physics. One professional bowler even got a masters degree in physics in hope that it would improve his game.

In this project, the student will be allowed to select and analyze a sports related activity. The project will include: (1) research historical development and technological advancements in the activity (2) design a scientific investigation to analyze the activity (3) summarize the results of the scientific investigation(s) and/or research to a larger community. Probable topics of study include motion, forces, impulse, momentum, vectors, energy transfer, and projectiles.

Materials:

- Various sporting equipment
- System to measure and analyze
- Presentation medium including but not limited to: dry erase boards, transparencies, PowerPoint, etc
- Any other equipment specified by students and approved by the teacher

Honors Physics Curriculum Support Document

Just Do It: Laboratory

Procedure:

1. Select a movement or activity from a sport that captivates your interest.
2. Investigate and analyze its relationship to physics and its fundamental concepts.
To accomplish this you should:
 - a. Identify the fundamental physics concepts of interest.
 - b. Research the aspect of interest of the sport as related to the fundamental physics concepts. Identify from your research a quantitative, answerable research question.
3. Answer your question utilizing sound scientific methodology. You should have your method approved before carrying out any experiment.
4. Analyze the collected data using physics equations and graphical analysis.
5. Present material to the class through an oral presentation and a research paper.

Safety:

Students should review standard laboratory safety procedures. Students need teacher approval for project selection, required materials and procedure **before** beginning the project.

Questions to Guide Project:

1. What sports do you enjoy? What movement will you study? What physics concepts are involved? What question can you research and analyze?
2. How will you research this activity? What equipment is required? What safety precautions should be observed? How will the data be collected?
3. Has the teacher approved the project?
4. What equations are needed to analyze the data? What are the different ways the data can be displayed? What does each display method tell us about the data?
5. How will the data and research be shared with the audience? What questions may the audience ask and how will the questions be answered?

Honors Physics Curriculum Support Document

Just Do It: Laboratory

Rubric:

Grading topic		1	2	3	4	Total points	
Research						<i>Self assessment</i>	<i>Teacher assessment</i>
1	Depth of topic	Too broad and open	Slightly broad	Slightly specific	Very specific		
2	Reference types	0	1-2	3-4	4+		
3	# of references	<3	4-5	6-7	8+		
Design							
1	Physics concepts	<ul style="list-style-type: none"> Basic terms and sketchy definitions given 	<ul style="list-style-type: none"> Clear basic definitions 	<ul style="list-style-type: none"> Personalized definitions 	<ul style="list-style-type: none"> Personalized definitions and connections between terms 		
2	Question to research	<ul style="list-style-type: none"> Question about basic sports activity 	<ul style="list-style-type: none"> Question includes physics topics 	<ul style="list-style-type: none"> Question includes physics topic with data to collect 	<ul style="list-style-type: none"> Question includes physics topic with data to collect and reasonable analysis 		
3	Experiment	<ul style="list-style-type: none"> Performs an activity with little concern over scientific data No safety precautions 	<ul style="list-style-type: none"> Performs an activity with some concern over scientific data Some safety precautions 	<ul style="list-style-type: none"> Performs a clear activity to collect data Some safety precautions 	<ul style="list-style-type: none"> Performs a clear activity to collect data for given question All safety precautions 		
Analysis							
1	Physics Concepts	<ul style="list-style-type: none"> Information on one physics topic No recent research No historical perspective 	<ul style="list-style-type: none"> Information on few physics topics Includes little recent research Lacks a historical perspective 	<ul style="list-style-type: none"> Information on several physics topics Includes little recent research Contains some historical perspective 	<ul style="list-style-type: none"> In-depth information on several physics topics Includes recent research Clear historical perspective 		

Honors Physics Curriculum Support Document

Just Do It: Laboratory

2	Mathematical Analysis	<ul style="list-style-type: none"> • Use of equations with many errors • Improper equations • Lacking information 	<ul style="list-style-type: none"> • Use of equations with few errors • Proper equations • Lacking information 	<ul style="list-style-type: none"> • No mathematical errors • Proper equations and substitution • Contains most information 	<ul style="list-style-type: none"> • No mathematical errors • Proper equations and substitution • Contains all information 		
3	Graphical Analysis	<ul style="list-style-type: none"> • Chart of data correctly labeled • No graphical representation 	<ul style="list-style-type: none"> • Chart of data correctly labeled • Meaningful graphical representation 	<ul style="list-style-type: none"> • Chart of data correctly labeled • Meaningful graphical representation • Explanation of graphical data 	<ul style="list-style-type: none"> • Chart of data correctly labeled • Meaningful graphical representation • Explanation of graphical data and clear conclusions based on data 		
Presentation							
1	Abstract/paper	<ul style="list-style-type: none"> • Many spelling & grammar errors • Improper length • Lacking information 	<ul style="list-style-type: none"> • Several spelling / grammar errors • Close to proper length • Lacking information 	<ul style="list-style-type: none"> • Few spelling / grammar errors • Proper length • Contains most information 	<ul style="list-style-type: none"> • No spelling / grammar errors • Proper length • Contains all information 		
2	Use of Media	<ul style="list-style-type: none"> • Uses only one media • Nothing to blend together 	<ul style="list-style-type: none"> • Uses 2 types media • Mediums blend roughly 	<ul style="list-style-type: none"> • Uses 3 types of media • Mediums blending more thoroughly 	<ul style="list-style-type: none"> • 4 types of media • Mediums blend smoothly. 		
3	Script / storyboards	<ul style="list-style-type: none"> • Flows poorly • Not followed at all 	<ul style="list-style-type: none"> • Flows decently • Not followed well 	<ul style="list-style-type: none"> • Flows smoothly • Mostly followed 	<ul style="list-style-type: none"> • Flows perfectly • Followed exactly 		
4	Answering questions	<ul style="list-style-type: none"> • Can not answer questions 	<ul style="list-style-type: none"> • Have difficulty answering questions 	<ul style="list-style-type: none"> • Answer question with little difficulty 	<ul style="list-style-type: none"> • Answer questions thoroughly 		

Honors Physics Curriculum Support Document

Catapult Project: Background Information

Catapult Project

Targeted *Standard Course of Study* Goals and Objectives:

- **COMPETENCY GOAL 1: The learner will develop abilities necessary to do and understand scientific inquiry.**
- **COMPETENCY GOAL 3: The learner will build an understanding of two-dimensional motion including circular motion.**
 - 3.01** Analyze and evaluate projectile motion in a defined frame of reference.
 - 3.02** Design and conduct investigations of two-dimensional motion of objects.
 - 3.03** Analyze and evaluate independence of the vector components of projectile motion.

Essential Question(s):

What are the factors affecting the range of a projectile launched from a catapult?

Introduction to the teacher:

Students will design and build a catapult that will allow them better understanding of 2 dimensional motion and to conduct an investigation using engineering skills including problem solving skills and group dynamics.

Project can be used to expand on Competency Goals 4, 5, and 6. Projects may be used throughout the year to demonstrate concepts in Goals 4, 5, and 6.

Differentiation from Standard-level:

This project is an independent engineering assignment which allows for student-directed exploration and experimentation of key physics concepts, such as two-dimensional motion. A large emphasis on data collection and analysis of that data, including projectile motion calculations and graphing relationships among factors that affect the range should be utilized in the honor classroom. If this project were to be used in a standard-level class, the teacher may direct the collection and analysis of data.

Safety/Special Considerations:

Students should be well versed in standard laboratory safety procedures. Students should have their catapult materials and experimental design approved by the teacher. Students should utilize materials that will not cause injury to themselves or others. Students should ensure that projectile pathway is clear. Students should create the most controlled environment possible.

Honors Physics Curriculum Support Document

Catapult Project: Laboratory

Catapult Project

Targeted *Standard Course of Study* Goals and Objectives:

- **COMPETENCY GOAL 1: The learner will develop abilities necessary to do and understand scientific inquiry.**
- **COMPETENCY GOAL 3: The learner will build an understanding of two-dimensional motion including circular motion.**
 - 3.01** Analyze and evaluate projectile motion in a defined frame of reference.
 - 3.02** Design and conduct investigations of two-dimensional motion of objects.
 - 3.03** Analyze and evaluate independence of the vector components of projectile motion.

Essential Question(s):

What are the factors affecting the range of a projectile launched from a catapult?

Introduction:

Throughout history, catapults have been central to many great stories between political and military powers. In this project, students will design and build a catapult that will provide a better understanding of two-dimensional motion, especially range. Each catapult will be presented with an explanation of the building process, a demonstration of their catapult, and an explanation of physics concepts with appropriate data analysis.

Materials:

Catapult should be student constructed by recycling household materials.

Procedure:

The teams will analyze data and present their finding to the class.

1. Research what a catapult is and how it works.
2. Develop a procedure for building a catapult.
3. Investigate and analyze two-dimensional motion and the factors that affect range. Research and experiment what factors affect the range of a catapult.
4. Analyze the collected data using physics equations and graphical analysis.
5. Present material to the class through an oral presentation and a research paper.

Safety/Special Considerations:

Students should be well versed in standard laboratory safety procedures. Students should have their catapult materials and experimental design approved by the teacher. Students should utilize materials that will not cause injury to themselves or others. Students should ensure that projectile pathway is clear. Students should create the most controlled environment possible.

Honors Physics Curriculum Support Document

Catapult Project: Laboratory

Questions to Guide Analysis:

1. What factors influence range of projectiles and what are the relationships among various factors that affect “hang time”, maximum height and range?
2. What is the relationship between angle of projectiles and range?
3. What is the relationship between “hang time” and range?

Honors Physics Curriculum Support Document

Catapult Project: Laboratory

Rubric:

Grading topic	1	2	3	4	Total points	
<i>Construction</i>					<i>Self assessment</i>	<i>Teacher assessment</i>
<ul style="list-style-type: none"> Functionality 	<ul style="list-style-type: none"> Catapult is non-functional 	<ul style="list-style-type: none"> Does not produce consistent results 	<ul style="list-style-type: none"> Produces fairly consistent results by estimating input factors 	<ul style="list-style-type: none"> Can accurately measure input factors and produces consistent results 		
<ul style="list-style-type: none"> Planning and Utilization of Materials 	<ul style="list-style-type: none"> Design lacks evidence of planning and forethought 	<ul style="list-style-type: none"> Design shows some evidence of planning and forethought with documentation 	<ul style="list-style-type: none"> Design and construction shows evidence of planning and utilization of household materials with appropriate documentation, but lacks aesthetic appeal 	<ul style="list-style-type: none"> Attractive and well-documented design and construction shows evidence of careful planning and utilization of household materials 		
<i>Science</i>						
<ul style="list-style-type: none"> Physics Laws and Concepts 	<ul style="list-style-type: none"> Basic terms and sketchy definitions given 	<ul style="list-style-type: none"> Clear basic definitions 	<ul style="list-style-type: none"> Personalized definitions 	<ul style="list-style-type: none"> Personalized definitions and connections between terms 		
<ul style="list-style-type: none"> Experimentation 	<ul style="list-style-type: none"> Performs an activity with little concern over scientific data No safety precautions 	<ul style="list-style-type: none"> Performs an activity with some concern over scientific data Some safety precautions 	<ul style="list-style-type: none"> Performs a clear activity to collect data Some safety precautions 	<ul style="list-style-type: none"> Performs a clear activity to collect data for given question All safety precautions 		

Honors Physics Curriculum Support Document

Catapult Project: Laboratory

<ul style="list-style-type: none"> Analysis of Data 	<ul style="list-style-type: none"> Use of equations with many errors Improper equations Lacking information Chart of data correctly labeled No graphical representation 	<ul style="list-style-type: none"> Use of equations with few errors Proper equations Lacking information Chart of data correctly labeled Meaningful graphical representation 	<ul style="list-style-type: none"> No mathematical errors Proper equations and substitution Contains most information Chart of data correctly labeled Meaningful graphical representation Explanation of graphical data 	<ul style="list-style-type: none"> No mathematical errors Proper equations and substitution Contains all information Chart of data correctly labeled Meaningful graphical representation Explanation of graphical data and clear conclusions based on data 		
<i>Presentation</i>						
<ul style="list-style-type: none"> Project Report 	<ul style="list-style-type: none"> Many spelling & grammar errors Improper length Lacking information 	<ul style="list-style-type: none"> Several spelling / grammar errors Close to proper length Lacking information 	<ul style="list-style-type: none"> Few spelling / grammar errors Proper length Contains most information 	<ul style="list-style-type: none"> No spelling / grammar errors Proper length Contains all information 		
<ul style="list-style-type: none"> Presentation 	<ul style="list-style-type: none"> Uses only one media Nothing to blend together Flows poorly Not followed at all 	<ul style="list-style-type: none"> Uses 2 types media Mediums blend roughly Flows decently Not followed well 	<ul style="list-style-type: none"> Uses 3 types of media Mediums blending more thoroughly Flows smoothly Mostly followed 	<ul style="list-style-type: none"> 4 types of media Mediums blend smoothly. Flows perfectly Followed exactly 		

Honors Physics Curriculum Support Document

Too Hot Research: Background Information

Too Hot Research

Targeted *Standard Course of Study* Goals and Objectives:

- **COMPETENCY GOAL 1: The learner will develop abilities necessary to do and understand scientific inquiry.**
- **COMPETENCY GOAL 6: The learner will develop an understanding of energy as the ability to cause change**

Essential Question(s):

How has thermodynamics influenced every day life?

Introduction to the Teacher:

This project allows students to research thermodynamics and present the information to a large group. Students are encouraged to look at how thermodynamics is involved in our everyday lives. The students will select a thermodynamic topic. The project will include: (1) research of historical discoveries, (2) discussion of technological advancements, and (3) analysis of how this topic influences everyday life including data.

Differentiation from Standard-level:

The project is an independent research experience of physics in a more abstract and quantitative level than the standard-level physics. Honors students will conduct their own research, produce written report, and produce a tangible, curriculum product. The project could be used in a more teacher-directed fashion or the presentations from the honors project could be used by the standard-level to introduce the physics phenomena.

Safety/Special Considerations:

Teachers should ensure that students are well versed in standard laboratory safety procedures. Teachers should refer to the NC Total Science Safety System software for specific guidelines.

References:

North Carolina Standard Course of Study
Honors Courses in North Carolina: Science

Honors Physics Curriculum Support Document

Too Hot Research: Project

Too Hot Research

Targeted *Standard Course of Study* Goals and Objectives:

- **COMPETENCY GOAL 1: The learner will develop abilities necessary to do and understand scientific inquiry.**
- **COMPETENCY GOAL 6: The learner will develop an understanding of energy as the ability to cause change**

Essential Question(s):

How has thermodynamics influenced every day life?

Introduction:

Have you ever wondered, “How was that discovered?” or “Why is it calculated that way?” This project will provide a vehicle to explore these questions and more especially “How does this topic affect my everyday life?” This project allows students to research thermodynamics and present the information to a large group. Students are encouraged to look at how thermodynamics is involved in our everyday lives. The students will select a thermodynamic topic. The project will include: (1) research of historical discoveries, (2) discussion of technological advancements, and (3) analysis of how this topic influences everyday life including data.

Materials:

- Scientific journals, publications, etc.

Procedure:

1. Select a thermodynamics topic that captivates your interest.
2. Research the history of the topic.
3. Identify how the topic has been studied in the past.
4. Research how the topic affects our every day life.
5. Present material to the class through an oral presentation and a research paper.

Safety/Special Considerations:

Students should observe proper research format as prescribed by the teacher and give proper reference for all information.

Questions to Guide Project:

1. What are the topics available in thermodynamics? What topic will you study? What fundamental physics concepts are involved? What question can you research specifically?

Honors Physics Curriculum Support Document

Too Hot Research: Project

2. How will you research this topic? What references are needed? How will the information be collected?
3. Has the teacher approved the topic?
4. How does the topic affect life? What data can be found in a reputable source? How can the data be analyzed? What equations are needed to analyze the data? What are the different ways the data can be displayed? What does each display method tell us about the data?
5. How will the data and research be shared with the audience? What questions may the audience ask and how will the questions be answered?

Honors Physics Curriculum Support Document

Too Hot Research: Project

Rubric:

Level		1	2	3	4	Total points	
Grading topic						<i>Self assessment</i>	<i>Teacher assessment</i>
Research							
1	Depth of topic	Too broad and open	Slightly broad	Slightly specific	Very specific		
2	Reference types	0	1-2	3-4	4<		
3	# of references	<3	4-5	6-7	8+		
Analysis							
1	Physics Concepts	<ul style="list-style-type: none"> Information on one physics topic No recent research No historical perspective 	<ul style="list-style-type: none"> Information on few physics topics Includes little recent research Lacks a historical perspective 	<ul style="list-style-type: none"> Information on several physics topics Includes little recent research Contains some historical perspective 	<ul style="list-style-type: none"> In-depth information on several physics topics Includes recent research Clear historical perspective 		
2	Mathematical Analysis	<ul style="list-style-type: none"> Use of equations with many errors Improper equations Lacking information 	<ul style="list-style-type: none"> Use of equations with few errors Proper equations Lacking information 	<ul style="list-style-type: none"> No mathematical errors Proper equations and substitution Contains most information 	<ul style="list-style-type: none"> No mathematical errors Proper equations and substitution Contains all information 		
3	Graphical Analysis	<ul style="list-style-type: none"> Chart of data correctly labeled No graphical representation 	<ul style="list-style-type: none"> Chart of data correctly labeled Meaningful graphical representation 	<ul style="list-style-type: none"> Chart of data correctly labeled Meaningful graphical representation Explanation of graphical data 	<ul style="list-style-type: none"> Chart of data correctly labeled Meaningful graphical representation Explanation of graphical data and clear conclusions based on data 		

Honors Physics Curriculum Support Document

Too Hot Research: Project

Level		1	2	3	4	Total points	
Grading topic						<i>Self assessment</i>	<i>Teacher assessment</i>
<i>Presentation</i>							
1	Abstract/paper	<ul style="list-style-type: none"> • Many spelling & grammar errors • Improper length • Lacking information 	<ul style="list-style-type: none"> • Several spelling / grammar errors • Close to proper length • Lacking information 	<ul style="list-style-type: none"> • Few spelling / grammar errors • Proper length • Contains most information 	<ul style="list-style-type: none"> • No spelling / grammar errors • Proper length • Contains all information 		
2	Use of Media	<ul style="list-style-type: none"> • Uses only one media • Nothing to blend together 	<ul style="list-style-type: none"> • Uses 2 types media • Mediums blend roughly 	<ul style="list-style-type: none"> • Uses 3 types of media • Mediums blending more thoroughly 	<ul style="list-style-type: none"> • 4 types of media • Mediums blend smoothly. 		
3	Script / storyboards	<ul style="list-style-type: none"> • Flows poorly • Not followed at all 	<ul style="list-style-type: none"> • Flows decently • Not followed well 	<ul style="list-style-type: none"> • Flows smoothly • Mostly followed 	<ul style="list-style-type: none"> • Flows perfectly • Followed exactly 		
4	Answering questions	<ul style="list-style-type: none"> • Can not answer questions 	<ul style="list-style-type: none"> • Have difficulty answering questions 	<ul style="list-style-type: none"> • Answer question with little difficulty 	<ul style="list-style-type: none"> • Answer questions thoroughly 		

Physics Curriculum Support Document

Independent Investigation Sample Rubric

Rubric:

Level		1	2	3	4	Total points	
Grading topic						<i>Self assessment</i>	<i>Teacher assessment</i>
Research							
1	Depth of topic	Too broad and open	Slightly broad	Slightly specific	Very specific		
2	Reference types	0	1-2	3-4	4<		
3	# of references	<3	4-5	6-7	8+		
Design							
1	Physics concepts	<ul style="list-style-type: none"> Basic terms and sketchy definitions given 	<ul style="list-style-type: none"> Clear basic definitions 	<ul style="list-style-type: none"> Personalized definitions 	<ul style="list-style-type: none"> Personalized definitions and connections between terms 		
2	Question to research	<ul style="list-style-type: none"> Question about basic idea 	<ul style="list-style-type: none"> Question includes physics topics 	<ul style="list-style-type: none"> Question includes physics topic with data to collect 	<ul style="list-style-type: none"> Question includes physics topic with data to collect and reasonable analysis 		
3	Experiment	<ul style="list-style-type: none"> Performs an activity with little concern over scientific data No safety precautions 	<ul style="list-style-type: none"> Performs an activity with some concern over scientific data Some safety precautions 	<ul style="list-style-type: none"> Performs a clear activity to collect data Some safety precautions 	<ul style="list-style-type: none"> Performs a clear activity to collect data for given question All safety precautions 		
Analysis							
1	Physics Concepts	<ul style="list-style-type: none"> Information on one physics topic No recent research No historical perspective 	<ul style="list-style-type: none"> Information on few physics topics Includes little recent research Lacks a historical perspective 	<ul style="list-style-type: none"> Information on several physics topics Includes little recent research Contains some historical perspective 	<ul style="list-style-type: none"> In-depth information on several physics topics Includes recent research Clear historical perspective 		

Physics Curriculum Support Document

Level		1	2	3	4	Total points	
Grading topic						<i>Self assessment</i>	<i>Teacher assessment</i>
2	Mathematical Analysis	<ul style="list-style-type: none"> • Use of equations with many errors • Improper equations • Lacking information 	<ul style="list-style-type: none"> • Use of equations with few errors • Proper equations • Lacking information 	<ul style="list-style-type: none"> • No mathematical errors • Proper equations and substitution • Contains most information 	<ul style="list-style-type: none"> • No mathematical errors • Proper equations and substitution • Contains all information 		
3	Graphical Analysis	<ul style="list-style-type: none"> • Chart of data correctly labeled • No graphical representation 	<ul style="list-style-type: none"> • Chart of data correctly labeled • Meaningful graphical representation 	<ul style="list-style-type: none"> • Chart of data correctly labeled • Meaningful graphical representation • Explanation of graphical data 	<ul style="list-style-type: none"> • Chart of data correctly labeled • Meaningful graphical representation • Explanation of graphical data and clear conclusions based on data 		
Presentation							
1	Abstract/paper	<ul style="list-style-type: none"> • Many spelling & grammar errors • Improper length • Lacking information 	<ul style="list-style-type: none"> • Several spelling / grammar errors • Close to proper length • Lacking information 	<ul style="list-style-type: none"> • Few spelling / grammar errors • Proper length • Contains most information 	<ul style="list-style-type: none"> • No spelling / grammar errors • Proper length • Contains all information 		
2	Use of Media	<ul style="list-style-type: none"> • Uses only one media • Nothing to blend together 	<ul style="list-style-type: none"> • Uses 2 types media • Mediums blend roughly 	<ul style="list-style-type: none"> • Uses 3 types of media • Mediums blending more thoroughly 	<ul style="list-style-type: none"> • 4 types of media • Mediums blend smoothly. 		
3	Script / storyboards	<ul style="list-style-type: none"> • Flows poorly • Not followed at all 	<ul style="list-style-type: none"> • Flows decently • Not followed well 	<ul style="list-style-type: none"> • Flows smoothly • Mostly followed 	<ul style="list-style-type: none"> • Flows perfectly • Followed exactly 		
4	Answering questions	<ul style="list-style-type: none"> • Can not answer questions 	<ul style="list-style-type: none"> • Have difficulty answering questions 	<ul style="list-style-type: none"> • Answer question with little difficulty 	<ul style="list-style-type: none"> • Answer questions thoroughly 		